

Lithium Series, Parallel and Series and Parallel Connections

Introduction

Lithium battery banks using batteries with built-in Battery Management Systems (BMS) are created by connecting two or more batteries together to support a single application. Connecting multiple lithium batteries into a string of batteries allows us to build a battery bank with the potential to operate at an increased voltage, or with increased capacity and runtime, or both.

To Series, Parallel, or Series and Parallel lithium batteries with a BMS you must first understand what a “true” BMS is, what it does, and what challenges the BMS in your battery may present to series, parallel, or series and parallel use.



ABOUT THE AUTHOR

Darwin Sauer is the CEO and founder of Discover Battery, and CEO and Chairman of the Board of Discover MIXTECH Manufacturing Co. Ltd. He is a visionary, innovator and entrepreneur with over 35 years of experience in the industry, and the driving force behind Discover's MIXTECH lineup of batteries and the acquisition of the MIXTECH plant in Korea.

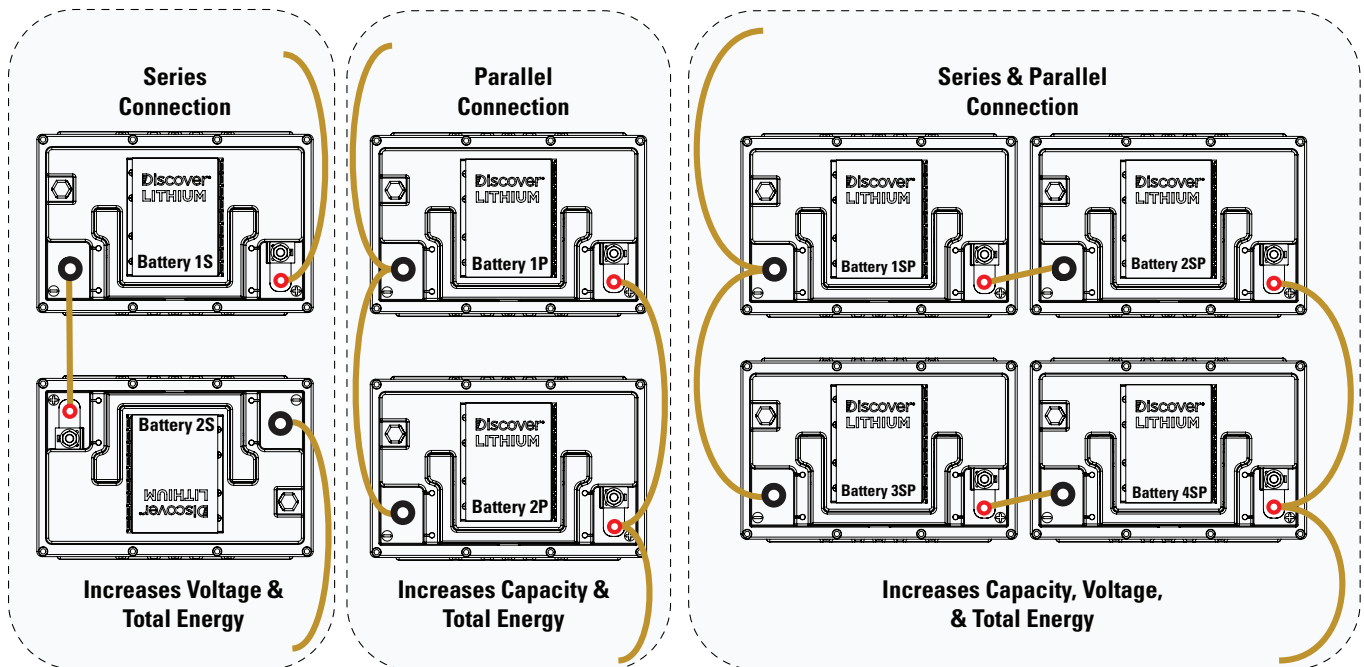

TABLE OF CONTENTS

1. What is a BMS, and why do you need a BMS in your lithium battery?	3
2. How to connect lithium batteries in series	4
2.1 Series Example 1: 12V nominal lithium iron phosphate batteries connected in series to create a 48V bank	4
2.2 Series Example 2: 12V nominal lithium iron phosphate batteries connected in series in a 36V bank	5
2.3 Series Example 3: 24V nominal batteries connected in series in a 48V nominal bank	5
3. How to connect lithium batteries in parallel	8
3.1 Lithium batteries are connected in parallel to...	8
3.2 Parallel Example 1: 12V nominal lithium iron phosphate batteries connected in parallel creating a higher capacity 12V bank	8
4. How to charge lithium batteries in parallel	14
4.1 Resistance is the enemy	14
4.2 How to charge lithium batteries in parallel from bad to best	15
5. How to connect lithium batteries in series and parallel/increasing both battery bank voltage and capacity	17

⚠ WARNING

Important information regarding hazardous conditions that may result in personal injury or death.

⚠ CAUTION

Important information regarding hazardous conditions that may result in minor to moderate injury.

NOTICE

Additional information concerning important procedures and features of the battery not related to physical injury.

NOTE

Application tip or useful information for the user.

1. What is a BMS? Why do you need a BMS in your lithium battery?

The primary function of a BMS is to ensure that each cell in the battery remains within its safe operating limits, and to take appropriate action to prevent the battery and its cell modules being used outside of their designed voltage, current, and temperature limits. More sophisticated BMS include increased cell balancing power, short-circuit protection, battery to battery communication, data-logging, auto fault reset, and communication capability with balance of systems components such as chargers, motor controllers, inverters, SOC gauges and on / off keys.

Anytime multiple connections are being made across multiple batteries, additional precautions must be given to safety, fusing, and short-circuit protection. It is important to understand that the majority of old generation lithium products were designed to only work in parallel, and the BMS was not designed to provide more than basic level protections. In fact, the BMS in these batteries would more appropriately be referred to as a simple protection circuit board (PCB) as it has little, if any, balancing power or short-circuit protection and it would not survive a reverse polarity event (the accidental reverse connection of battery cables with the battery terminals).

Most legacy BMS designs in the marketplace are not capable of protecting a true short circuit as advertised. Many are designed to manage a maximum 20 milliohm short circuit (a flawed interpretation of the UL 1973 limit) which for high energy deep-cycle lithium batteries is not representative of a short circuit at all but more like a slightly higher than normal high-rate load current.

For example:

1. A typical 12V lithium battery built to manage 20 milliohms (20 mechanical relay - .02) in short-circuit protection would be limited to 600 amps of current.
 - a. $12V / 0.02m\Omega R = 600A$ (*see Ohms Law!*)
2. A Discover 12V lithium battery is built with no more than 20 micro-ohms (20uR) of resistance so short circuit protection is at least 6000 amps.
 - b. $12V / .002m\Omega R = 6000A$ (*see Ohms Law!*)

Designing to lower resistance (ΩR) is better. Designing short circuit and reverse polarity protection capability to a much lower external resistance limit is safer and better protects your investment against accidental misuse or abuse. A high-quality design is low enough to provide maximum fault current protection that is more like the bolted short circuit current used in arc-flash studies and certifications.

At Discover, this means designing our solid-state-relay (SSR) and mechanical relay style BMS with dynamic reverse polarity and short circuit protection features that provide safe interruption of >6000 Amps or more (depending on battery voltage) and that will block or clamp at least double the individual battery's voltage.

The cost and overall quality of the BMS in your lithium battery, whether an SSR or mechanical relay design, is directly proportionate to its ability for blocking voltage spikes and its full load current rating. Adding true reverse polarity protection and true short circuit protection raises the cost. But, as it is easy for a person in a confined installation space such as in a boat, RV or truck to accidentally reverse connect or improperly short circuit battery terminals with wrenches while work is being done on a parallel or series battery bank installation, the cost is worth it if it ensures product robustness and OEM, distributor, installer and end user safety and satisfaction.

The lithium battery BMS, its design and primary purpose:

- The primary purpose of a BMS is to interrupt the charge and discharge process if cell and battery voltage, cell and battery current and cell and BMS temperatures go outside of their designed operating specifications
- To obtain battery level safety, transportation and performance certifications by independent industry bodies (such as UL or IEC), the BMS in the finished battery must be tested and proven to work according to the cell and the battery's published specifications and include temperature tests at both the cell level and the BMS level during high continuous current testing. ***Most Lithium batteries only have UL and IEC certifications at the cell level.***

Figure 2. Series Connection 4 x 6V = 24V

- A BMS will use either a SSR (made of mosfets), or a mechanical relay. Both SSR and mechanical relays have pros and cons, and both of them have their own voltage and current limitations.
- With a SSR, mosfets are connected in parallel on the PCB board and the heat sink. Mosfets are like conductors so the more you have in parallel the more current the BMS can handle.
- Like conductors, when the voltage (pressure) is going too high, the mosfets can't actually stop the current that is rushing through them and causing the high voltage condition. This creates lots of heat that can destroy the mosfets in a cascading fashion so the higher the mosfets current rating and the more mosfets there are, the better the design. On the plus side SSR can be switched on and off incredibly fast and fast enough to interrupt short circuits if the BMS is programmed and designed correctly. Even so, many in-rush loads such as the in-rush loads that occur when turning on an inverter or electric motor, can look like a short circuit to the sophisticated short-circuit detection of the BMS designed with a SSR causing it to protect inadvertently.
- Also, the mosfets on a SSR have maximum voltage ratings. The higher the mosfets voltage rating the better it is if connecting the BMS in series with other BMS. The down side is the higher the mosfets voltage rating, the higher the batteries internal resistance, so it will generate more heat.
- SSR will create a lot more internal heating when operating at extended high continuous currents as compared to a mechanical relay and the BMS must be designed with large heat sinks to handle this heating. So, the more mosfets in the design the better but it also requires larger heat sinks to manage the heat.
- Part of the independent testing for certification measures the ability of the BMS SSR heat sink to dissipate heat safely at maximum operating limits. If a lithium battery has continuous current limits of less than 1x its rated capacity in amp-hours it is because the BMS does not have enough mosfets; its heat sink design is too small to dissipate the heat generated by the mosfets at extended high continuous charge or discharge currents, or both not enough mosfets or heat dissipation capability.
- A high-quality battery with an SSR BMS design will also include an external fuse to provide an extra level of protection for the user and their investment against high in-rush currents. It is better to blow a fuse that costs a few dollars and is easy to replace than to destroy a valuable investment.
- With mechanical relays, it is the mechanical relay itself that has a maximum voltage rating. When the voltage is too high, the load or charge currents may arc across the mechanical relay contacts and cause damage. Arcing usually happens when the voltage is way higher than the mechanical relay is rated for. Mechanical relays are slower to react than SSR making protection against short circuits more difficult so external fusing must be added to the BMS designed with a mechanical relay. Remember that individual lithium cells have their own fusing mechanisms, so you don't want short circuit current going through the cells or the battery will be damaged beyond repair. A user replaceable fuse is an extra level of protection for the user and their investment.
- Because mechanical relay contacts may arc if hit with voltage or currents that are too high, a BMS design that uses mechanical relays must also include pre-charge circuits that are able to handle higher than expected in-rush currents.
- Discover's BMS designs have proprietary pre-charge circuits, hardware and firmware with load qualification architecture that recognizes if the load being turned on is benign, is a short-circuit event, or is part of a reverse polarity connection.

2. How to connect lithium batteries in series

Lithium batteries are connected in series when the goal is to increase the nominal voltage rating of one individual lithium battery - by connecting it in series strings with at least one more of the same type and specification - to meet the nominal operating voltage of the system the batteries are being installed to support. Connecting batteries in series incrementally adds the voltage and stored energy potential of each battery connected in the series string without changing the total amp-hour capacity of the completed battery bank.

No matter the BMS design, because both solid-state-relays and mechanical relays have voltage limits, the BMS maximum voltage limits must be respected when designing a series connected bank of lithium batteries with built in BMS.

2.1 Series example 1: 12V nominal LiFePO₄ batteries connected in series to create a 48V bank

- Start by knowing the maximum voltage limits of the BMS in each battery (not just the published high charging voltage protection limits). For example:
 - 80V for Discover's Lithium BLUE models
 - 60V for Discover's Lithium PRO models
 - 100V for Discover's Lithium AES models

- Discover's 12V LiFePO₄ batteries have a nominal voltage rating of 12.8Vn and the BMS will protect at the maximum operating voltage of 14.6V.
- A bank of 4 x 12Vn LiFePO₄ batteries connected in series will have a nominal voltage of 51.2Vn and a maximum operating voltage of 58.4V.
- Each battery in the string has the potential to see the total battery bank voltage across its relays during switching (operation)
- The BMS in each 12.8Vn battery in the series string must be capable of switching at least the max. operating voltage of 58.4V
- When charging, periodically each battery's balancing circuits must be allowed to operate for cell balancing purposes. Allow the balancing circuits to operate for as long as possible (8 hours is a good limit) at the batteries published balancing/absorption voltage
- Just like with high-quality lead acid batteries, if you wish to lengthen their high-performance life, periodic cell balancing should be performed. The BMS in a high-quality LiFePO₄ lithium battery will start to balance at 3.35Vpc - 3.40Vpc. Designs that wait until cells are at their max voltage are bad designs that reflect a serious lack of understanding of lithium cell electro-chemistry and performance characteristics.

2.2 Series Example 2: 12V nominal LiFePO₄ batteries connected in series in a 36V bank

- Start by knowing the Maximum voltage limits of the BMS in each battery (not just the published high charging voltage protection limits). For example:
 - 80V for Discover's Lithium BLUE models
 - 60V for Discover's Lithium PRO models
 - 100V for Discover's Lithium AES models
- Discover's 12V LiFePO₄ Batteries have a nominal voltage rating of 12.8Vn and the BMS will protect at the max. operating voltage of 14.6V
- A bank of 3 x 12.8Vn LiFePO₄ batteries connected in series will have a nominal voltage of 38.4Vn and a max. operating voltage of 43.8V
- Each battery in the string has the potential to see the total battery bank voltage across its relays during switching (operation)
- The BMS in each 12.8Vn battery in the series string must be capable of switching at least the max. operating voltage of 43.8V
- When charging, periodically each battery's balancing circuits must be allowed to operate for cell balancing purposes. Allow the balancing circuits to operate for as long as possible (8 hours is a good limit) at the batteries published balancing/absorption voltage.
- Just like with high-quality lead acid batteries, if you wish to lengthen their high-performance life, periodic cell balancing should be performed. The BMS in a high-quality LiFePO₄ lithium battery will start to balance at 3.35Vpc - 3.40Vpc. Designs that wait until cells are at their max voltage are bad designs that reflect a serious lack of understanding of lithium cell electro-chemistry and performance characteristics.

2.3 Series Example 3: 24V nominal LiFePO₄ batteries connected in series in a 48V bank

- Start by knowing the Maximum voltage limits of the BMS in each battery (not just the high voltage protection settings). For example:
 - 60V for Discover's Lithium BLUE models
 - 60V for Discover's Lithium PRO models
 - 100V for Discover's Lithium AES models
- Discover's 24V LiFePO₄ Batteries have a nominal voltage rating of 25.6Vn and the BMS will protect at the max. operating voltage of 29.2V

- A bank of 2 x 25.6Vn batteries connected in series will have a nominal voltage of 51.2Vn and a max. operating voltage of 58.4V
- Each battery in the string has the potential to see the total battery bank voltage across its relays during switching (operation)
- The BMS in each 25.6Vn battery in the series string must be capable of switching at least the max. operating voltage of 58.4V.
- When charging, periodically each battery's balancing circuits must be allowed to operate for cell balancing purposes. Allow the balancing circuits to operate for as long as possible (8 hours is a good limit) at the batteries published balancing/absorption voltage.
- Just like with high-quality lead acid batteries – if you wish to lengthen their high-performance life – periodic cell balancing should be performed. The BMS in a high-quality LiFePO4 lithium battery will start to balance at 3.35Vpc-3.40Vpc. Designs that wait until cells are at their max voltage are bad designs that reflect a serious lack of understanding of lithium cell electro-chemistry and performance characteristics.

⚠ CAUTION

Anytime we consider making multiple connections across multiple batteries we must take safety into consideration and pay close attention to fusing, short-circuit, accidental grounding and reverse-polarity protection as we make the many connections. Extreme caution and attention to detail must be taken to avoid improper cabling and terminal connections and to avoid terminal arching. In addition to the personal risks presented, battery or BMS damage from arch faults or short circuits will void warranty.

NOTICE

If a lithium battery and/or its BMS is destroyed from an over voltage event its warranty will be voided. So, while in theory even if a manufacturer states that you **can** connect their batteries in series, the battery bank may still fail as switching voltage across relays can actually be 2-3 times the bus (total system) voltage due to the potential for unanticipated electrical currents, battery balancing issues, and electromotive forces or snapbacks that drive peak system voltage over the voltage protection capability of the BMS in any one of the individual batteries in the string. These events are not within the manufacturers control.

Two 12.8 Volt lithium batteries connected in series become a single 25.6 Volt battery bank by connecting the **NEG. (-)** terminal of Battery 1 to the **POS. (+)** terminal of Battery 2. **DO NOT ATTEMPT to CONNECT** the last open **POS. (+)** of Battery 1 to the last open **NEG. (-)** of Battery 2. This will cause a battery explosion or arch fault that will melt the terminals.

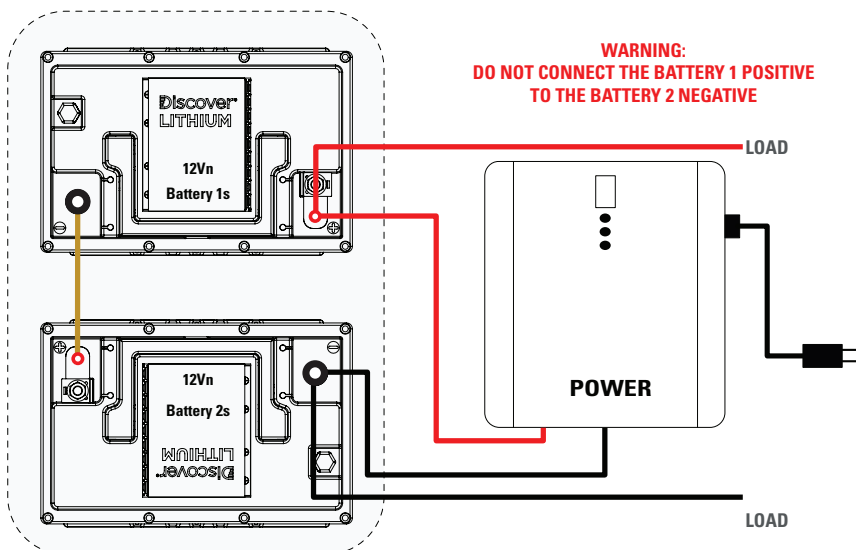

If there are only two batteries in the series string (Figure 1), we would then take a cable from the open **POS. (+)** terminal of the first battery and a cable from the open **NEG. (-)** of the second (last) battery in the string to the load and charger/power source.

The series connection shown in Figure 1 DOES NOT increase your amp hour capacity. This series connection only increases the total voltage (12.8V+12.8V = 25.6V) and the total stored energy potential in watts. If each 12.8V battery in the string was rated at 100 Amp hour to 100% DOD, the final battery bank rating would be 25.6V 100AH and would have a total of 2560 watts of stored energy to 100% DOD.

Figure 1: Series Connection 2 x 12.8Vn = 25.6Vn. BMS will protect at 29.2V

NOTE

“Volts x Amps = Watts”: One 12.8V-100AH lithium battery has 1280 Watts of stored energy potential. Two 12.8V-100AH lithium batteries connected in series becomes a 25.6V-100AH battery bank with 2560 watts of stored energy potential to 100% DOD. Connecting batteries in Series increases the battery bank voltage and total stored energy.

NOTE

Installers should carefully consider the use of BUS bars for permanent connections of charges and loads and/or easy disconnect cable ends for rapid interchanging between loads and chargers.

NOTICE

Even though it is possible, the recommended depth of discharge (DOD) for high-quality deep-cycle lithium batteries is not 100%. Most responsible manufacturers will recommend between 80% and 90% depending upon application. Unlike lead-acid batteries, lithium battery life can be exponentially extended if they are constantly operated in a partial state of charge between 90% SOC (10% DOD) and 10% SOC (90% DOD).

If you need even more voltage you will need to connect more batteries in series.

To increase battery bank voltage, continue the **NEG. (-)** terminal to **POS. (+)** terminal pattern of connection shown in Figure 1 until you reach your desired nominal operating voltage. Figure 2 illustrates four 12.8Vn lithium batteries connected in series to achieve 51.2Vn. **DO NOT ATTEMPT to CONNECT** the open **POS. (+)** on Battery 1 in the string to the final open **NEG. (-)** terminal on Battery 4. This will cause a battery explosion or arc fault that will melt the terminals.

The Figure 2 series connection **DOES NOT** increase your amp hour capacity; it only increases the total nominal voltage (12.8V+12.8V+12.8V+12.8V = 51.2Vn) and the total stored energy in watts. If each 12.8Vn battery in the string was rated at 100 Amp hour to 100% DOD, the final battery bank rating would be 51.2V 100AH and it would have a total of 5120 watts of stored energy potential to 100% DOD.

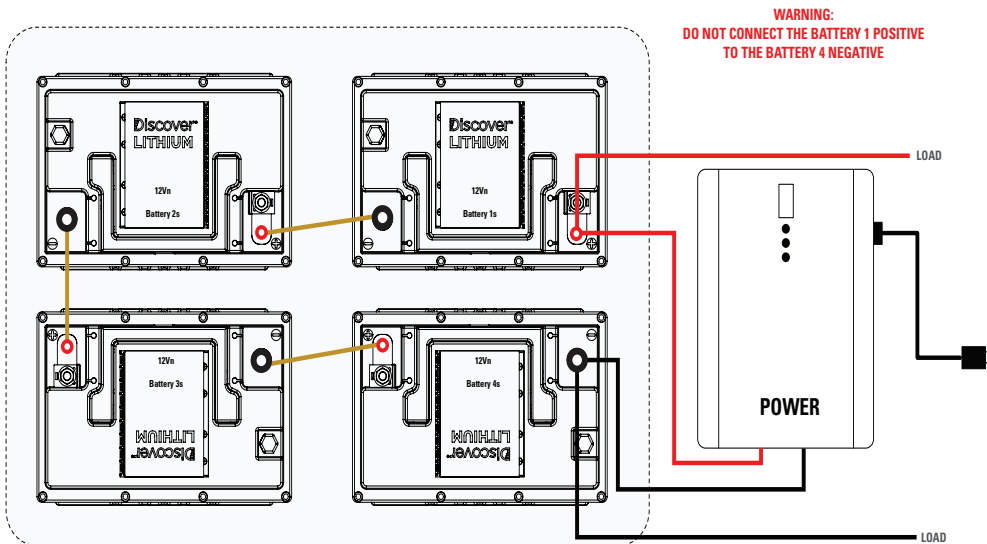

Figure 2: Series Connection 4 x 12.8Vn. BMS will protect at 58.4V

NOTE

“Volts x Amps = Watts”: One 12.8V-100AH lithium battery has 1280 Watts of stored energy potential. Four 12.8V-100AH lithium batteries connected in series becomes a 51.2V-100AH battery bank with 5120 watts of stored energy potential to 100% DOD. Connecting batteries in Series increases the battery bank voltage and its total stored energy.

NOTE

Installers should carefully consider the use of BUS bars for permanent connections of charges and loads and/or easy disconnect cable ends for rapid interchanging between loads and chargers.

NOTICE

Even though it is possible, the recommended depth of discharge (DOD) for high-quality deep-cycle lithium batteries is not 100%. Most responsible manufacturers will recommend between 80% and 90% depending upon application. Unlike lead-acid batteries, lithium battery life can be exponentially extended if they are constantly operated in a partial state of charge between 90% SOC (10% DOD) and 10% SOC (90% DOD).

The examples in Figure 1 and 2 used 12.8Vn LiFePO₄ batteries. If you use LiFePO₄ batteries with different individual voltages: 24V(25.6V), 36V(37.4V), 48V(51.2V), the method of connecting POS. to NEG. as you progress through the string of batteries will be the same.

NOTICE

Instead of making series connections of 12V lithium batteries we strongly suggest that paralleling higher voltage models to achieve your desired battery bank configuration is far better and safer. View Figure 5 on how to connect lithium batteries in parallel.

3. How to connect lithium batteries in parallel

3.1 Lithium batteries are connected in parallel to:

- Increase the amp-hour capacity of a battery bank without increasing its voltage
- Increase the maximum continuous operating current limits of the batteries internal BMS

This is very prevalent in 12-volt and 24-volt RV and Marine house battery bank installations. Lithium Batteries are connected in parallel strings to meet the required capacity or run-time of the loads the battery bank will need to support, and to parallel up the capacity of the individual BMS to support the in-rush currents that equipment such as large inverters or electric motors may require during start up if the operating limits of the BMS in one battery are not sufficient.

NOTE

No matter the BMS design, because both solid-state-relays and mechanical relays have current limits, the BMS maximum current limits must be respected when designing a parallel connected bank of lithium batteries with built in BMS.

NOTICE

Good system design dictates that the finished parallel battery banks maximum continuous current limits be derated by 10%.
(BMS#1 + BMS#2) x .90% = battery bank maximum continuous current rating.

3.2 Parallel Example 1: 12V nominal LiFePO₄ batteries connected in parallel creating a higher capacity 12V bank

- Start by knowing the maximum continuous current limits of the BMS in each battery (not just the high current protection settings)
- Determine maximum discharge or charge currents that can be applied to the battery bank from the loads and charge sources

- Make sure the combined continuous current ratings of the paralleled BMS can support the maximum load and charge currents
- Understand that if one battery fails, the potential currents will then be shared across fewer BMS in the parallel string
- When charging, periodically each battery's balancing circuits must be allowed to operate for cell balancing purposes. Allow the balancing circuits to operate for as long as possible (8 hours is a good limit) at the batteries published balancing/absorption voltage
- Just like with high-quality lead acid batteries – if you wish to lengthen their high-performance life – periodic cell balancing should be performed. The BMS in a high-quality LiFePO₄ lithium battery will start to balance at 3.35Vpc-3.40Vpc. Designs that wait until cells are at their max voltage are bad designs that reflect a serious lack of understanding of lithium cell electro-chemistry and performance characteristics.

⚠ CAUTION

Anytime we consider making multiple connections across multiple batteries we must take safety into consideration and pay close attention to fusing, short-circuit, accidental grounding and reverse-polarity protection as we make the many connections. Extreme caution and attention to detail must be taken to avoid improper cabling and terminal connections and to avoid terminal arching. In addition to the personal risks presented, battery or BMS damage from arch faults or short circuits will void warranty.

⚠ CAUTION

In theory, there is no limit to the number of batteries that can be paralleled into a larger battery bank. However, anytime we consider making multiple connections across multiple batteries we must take safety into consideration and pay close attention to fusing, short-circuit, accidental grounding and reverse-polarity protection as we make the many connections. Extreme caution and attention to detail must be taken to avoid improper cabling and terminal connections and to avoid terminal arching. In addition to the personal risks presented, battery or BMS damage from arch faults or short circuits will void warranty.

NOTICE

With lithium batteries DO NOT subject the battery(s) to currents or temperatures that exceed their BMS design limits. Check with your manufacturer. If a lithium battery and/or its BMS is destroyed from an over current or over temperature event its warranty will be voided. So, while in theory, even if a manufacturer states that you can connect their batteries in parallel, individual batteries or the total battery bank may still fail if current and/or temperature limits exceed the BMS design thresholds due to the potential for unanticipated electrical currents, battery balancing issues, individual battery failure within the bank, and electromotive forces or snapbacks that drive peak system currents or temperature events over the current or temperature protection capability of the BMS in any one of the individual batteries in the string. These events are not within the manufacturers control. Good system designers should build in margins of error.

In Figure 3, by connecting the **NEG. (-)** terminal of Battery 1 to the **NEG. (-)** terminal of Battery 2 and the **POS. (+)** terminal of Battery 1 to the **POS. (+)** of Battery 2, two 12.8Vn lithium batteries connected in parallel become a single 12.8-volt nominal lithium battery bank with two times the capacity and stored energy potential and up to 2x the maximum current ratings of a single lithium battery's and its BMS.

If there are only two batteries in the parallel string, we would then take a cable from the **POS. (+)** terminal of Battery 1 to the charger. We would use the **POS. (+)** terminal of Battery 2 for connection to the loads. We complete the installation by connecting a cable from the Battery 1 **NEG. (-)** to the loads, leaving the Battery 2 **NEG. (-)** to be connected to the power/charging source.

The parallel connection shown in Figure 3 DOES NOT increase your battery bank voltage. Parallel connections increase the total capacity and the total stored energy potential of the finished bank. It also increases the maximum potential continuous charge and discharge currents by a multiple of up to 2x. (Good system design dictates this be derated by no less than 10%). If each 12.8Vn lithium battery was rated at 100 Amp hour (1Hr) to 100% DOD with a 100A maximum continuous discharge rating, the final battery bank rating would be 12.8Vn-200AH (2560 watts) with a continuous discharge current rating of 200 amps.

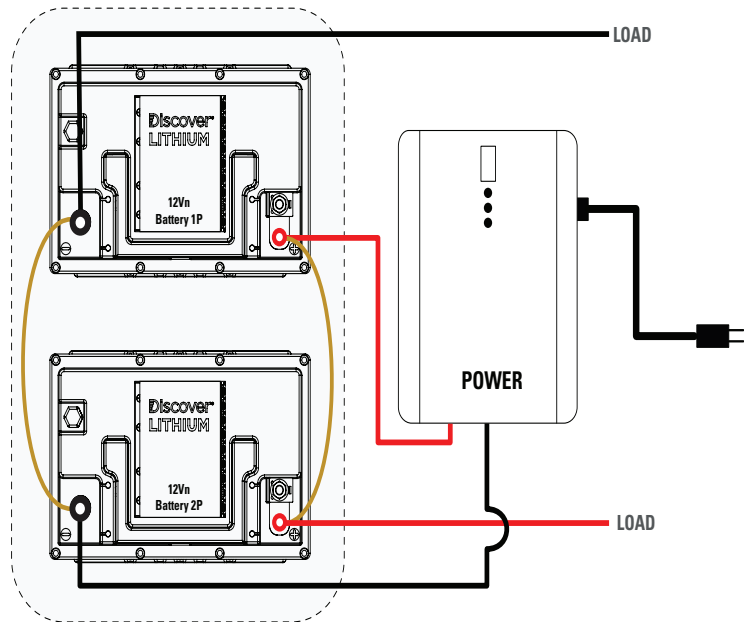

Figure 3: Parallel connection of 2 x 12.8Vn 100Ah batteries each with a BMS designed to support a 100A continuous discharge rating becomes a 12.8V - 200Ah battery bank with a combined 200A continuous discharge rating

NOTE

“Volts x Amps = Watts”: One 12.8Vn x 100AH = 12V x 100AH or 1280 Watts of stored energy. Two 12.8Vn x 100AH in parallel = 25.6Vn -200AH with 2560 Watts of stored energy. Connecting lithium batteries in parallel increases the battery bank capacity and the total stored energy.

NOTE

No matter the BMS design, because both solid-state-relays and mechanical relays have current limits, the BMS maximum current limits must be respected when designing a parallel connected bank of lithium batteries with built in BMS.

NOTICE

Even though it is possible, the recommended depth of discharge (DOD) for high-quality deep-cycle lithium batteries is not 100%. Most responsible manufacturers will recommend between 80% and 90% depending upon application as lithium battery life can be exponentially extended if they are constantly operated in a partial state of charge between 90% SOC (10% DOD) and 10% SOC (90% DOD).

NOTICE

Good system design dictates that the finished parallel battery banks maximum continuous current limits be derated by 10%. (BMS#1 + BMS#) x .90% = battery bank maximum continuous current rating.

If you need even more capacity you will need to connect more batteries in parallel.

Figure 4 DOES NOT increase your battery bank voltage. This parallel connection increases the total capacity and the total stored energy potential of the finished bank. It also increases the maximum potential continuous charge and discharge current of each single battery by up to 4x. If each 12.8V nominal lithium battery was rated at 150 Amp hour to 100% DOD with a BMS capable of managing 150 amps of continuous current, the final battery bank capacity would be 12.8Vn-600AH (7680 watts) with a maximum continuous current rating of up to 600 amps.

NOTE

"Volts x Amps = Watts": One 12.8Vn-150AH=12.8Vn-150AH with 1920 Watts of stored energy potential. Four 12.8Vn-150AH in parallel = 12.8Vn-600AH with 7680 Watts of stored energy potential to 100% DOD.

NOTE

No matter the BMS design, because both solid-state-relays and mechanical relays have current limits, the BMS maximum current limits must be respected when designing a parallel connected bank of lithium batteries with built in BMS.

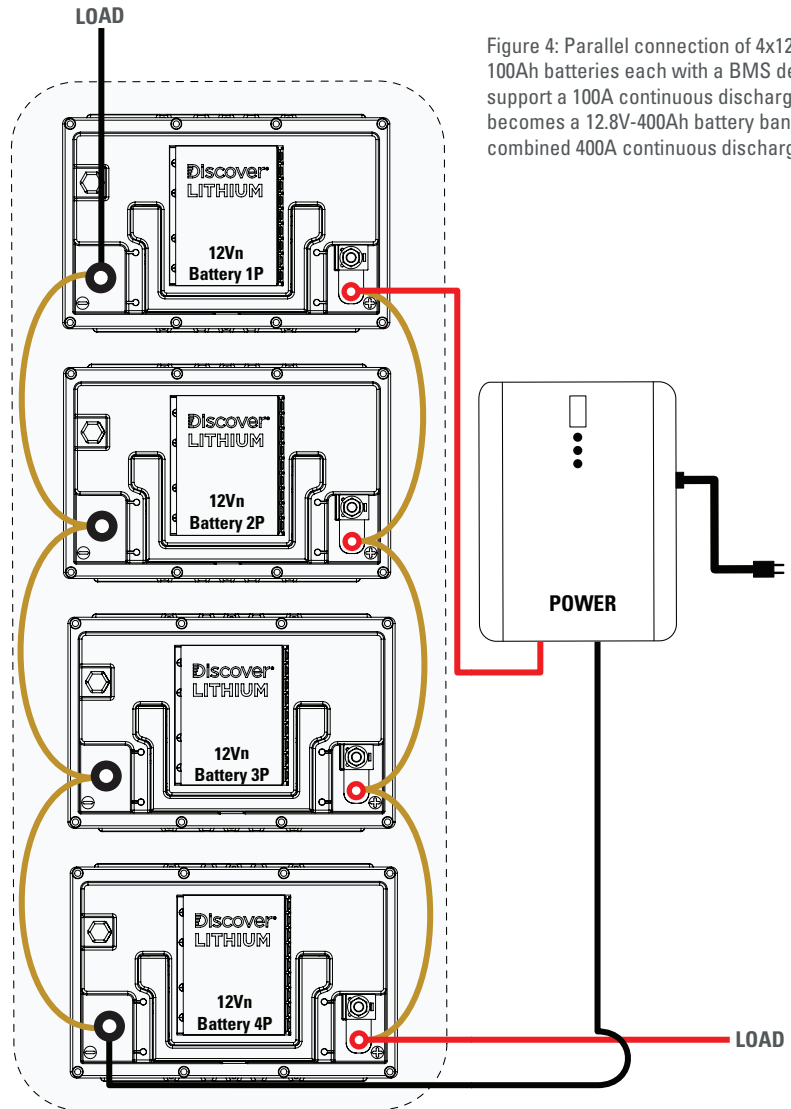

Figure 4: Parallel connection of 4x12.8Vn 100Ah batteries each with a BMS designed to support a 100A continuous discharge rating becomes a 12.8V-400Ah battery bank with a combined 400A continuous discharge rating.

NOTICE

Even though it is possible, the recommended depth of discharge (DOD) for high-quality deep-cycle lithium batteries is not 100%. Most responsible manufacturers will recommend between 80% and 90% depending upon application as lithium battery life can be exponentially extended if they are constantly operated in a partial state of charge between 90% SOC (10% DOD) and 10% SOC (90% DOD).

NOTICE

Good system design dictates that the finished parallel battery banks maximum continuous current limits be derated by 10%. $(\text{BMS\#1} + \text{BMS\#2} + \text{BMS\#3} + \text{BMS\#4}) \times .90\% = \text{battery bank maximum continuous current rating}$.

NOTE

Installers should always avoid connecting loads and charging/power sources to the same battery in a parallel string. Properly ensuring that loads and charging source connections are made to opposing ends of the string will ensure the bank stays in a more balanced state and can prevent premature battery failure.

The examples in Figures 3 and 4 used 12.8V nominal lithium batteries. If you use lithium batteries with different individual nominal voltages 24V(25.6V), 36V(37.4V), 48V(51.2V), the method of connecting **POS. (+) to POS. (+)** and **NEG. (-) to NEG. (-)** as you progress through the parallel string will be the same. Plus, it is a far better option to parallel higher voltage lithium batteries than to series or series and parallel lower voltage lithium battery models.

If you need higher voltage battery banks with even more capacity you will need to connect more batteries in parallel and potentially parallel multiple strings of batteries into a battery bank with excellent redundancy.

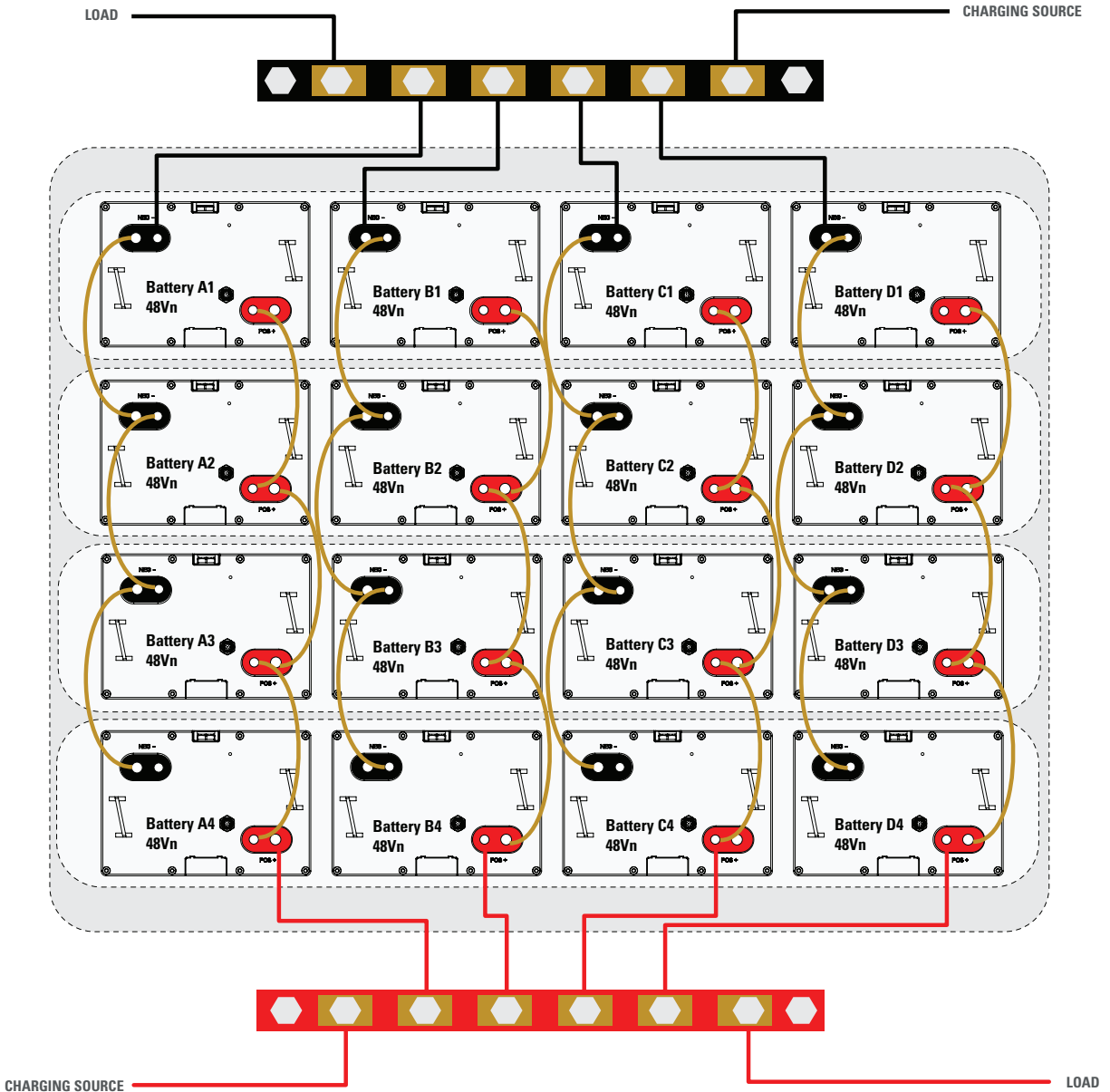

Figure 5: Illustrates 4 strings of 48V nominal 30AH lithium batteries connected in parallel and then paralleled onto negative and positive BUS bars creating a 48V 480AH battery bank

Figure 5 DOES NOT increase the voltage of the individual batteries in the bank. Each lithium battery in the bank is a 51.2Vn 30AH lithium battery with a BMS capable of managing 30A of continuous charge or discharge current. By connecting 4 x 51.2V 30AH batteries in parallel each string becomes a 51.2V 120AH string capable of handling up to 120 amps of continuous current. Each of the four strings is then

paralleled onto positive and negative BUS bars creating a 51.2V 480AH battery bank capable of supporting up to 480 amps of continuous current. This type of battery bank provides excellent redundancy should a battery in a string or a total string fail as the battery bank will still be able to sustain the electrical system voltage although with reduced capacity.

NOTE

“Volts x Amps = Watts”: One 51.2Vn-30AH battery has 1536 Watts of stored energy potential and a maximum continuous current rating of 30 amps. Four 51.2Vn-30AH in parallel = 51.2Vn-120AH with 6144 Watts of stored energy potential. Four strings paralleled becomes a 51.2Vn-480AH (24576 watt) battery bank with a maximum continuous current rating of 480 amps.

⚠ CAUTION

For increased safety and for easy disconnection of one string from the bank when service is required, isolation breakers should be installed. Install isolation breakers between string A and the BUS bar, and string B and the BUS bar, and string C and the BUS bar, and string D and the BUS bar (and so on if adding more strings) for increased safety and for easy isolation of one string should service be required.

NOTICE

Proper battery bank design and redundancy ensure that the finished parallel battery banks maximum continuous current rating capability is 1.5x - 2x the electrical systems actual maximum continuous load or charge current potential.

Paralleling higher voltage batteries is better and provides both an increase in capacity and stored energy potential, and increased current carrying capacity to support large inverter and electric motor loads.

Discover has a wide range of Lithium battery voltage options including 12V(12.8V), 24V(25.6V), 36V(37.4V), and 48V(51.2V) models that make it convenient to safely build parallel battery banks with individual batteries that are already at the desired electrical system voltage. Unlike series connecting lower voltage models, by paralleling these higher voltage models you can be sure that every battery in the bank has the ability to manage the total bank voltage.

As shown below in battery bank A, B, and C, making parallel connections of higher voltage lithium batteries increases the redundancy and overall performance of the electrical system versus series connecting lead-acid batteries. As many as 20, or as few as two Discover Lithium PRO series batteries can be connected to build the desired battery bank.

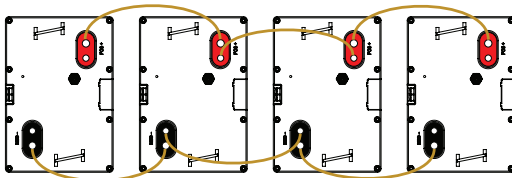

To build a 24V battery bank

Parallel as many Discover DLP GC-24V Lithium as needed vs. Series connecting 4 x lead-acid GC-6V golf cart battery types.

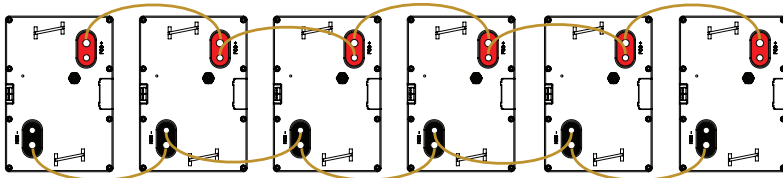

To build a 36V battery bank

Parallel as many Discover DLP GC-36V Lithium as needed vs. Series connecting 6 x lead-acid GC-6V golf cart battery types.

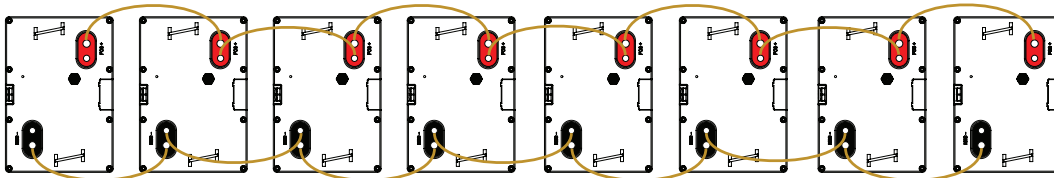

To build a 48V battery bank

Parallel as many Discover DLP GC-48V Lithium as needed vs. Series connecting 8 x lead-acid GC-6V or 6 x lead-acid GC-8V golf cart battery types

Most Discover Lithium PRO series batteries are designed with dual terminal options making it easy to make low resistance inter-battery connections without applying more than one cable to each terminal.

NOTICE

Discover's AES and PRO series lithium batteries include the advanced features installers look for when building larger battery banks such as increased cell balancing power, short-circuit protection, battery to battery communication, data-logging, auto fault reset and CAN communication capability with balance of systems components such as chargers, motor controllers, inverters, SOC gauges and on/off keys. In addition, most models are equipped with field serviceable fuses for an extra level of protection against misuse or abuse.

⚠ CAUTION

In theory, there is no limit to the number of batteries that can be paralleled into a larger battery bank. However, anytime we consider making multiple connections across multiple batteries we must take safety into consideration and pay close attention to fusing, short-circuit, accidental grounding and reverse-polarity protection as we make the many connections. Extreme caution and attention to detail must be taken to avoid improper cabling and terminal connections and to avoid terminal arching. In addition to the personal risks presented, battery or BMS damage from arch faults or short circuits will void warranty.

NOTICE

With lithium batteries DO NOT subject the battery(s) to currents or temperatures that exceed their BMS design limits. Check with your manufacturer. If a lithium battery and/or its BMS is destroyed from an over current or over temperature event its warranty will be voided. So, while in theory, even if a manufacturer states that you can connect their batteries in parallel, individual batteries or the total battery bank may still fail if current and/or temperature limits exceed the BMS design thresholds due to the potential for unanticipated electrical currents, battery balancing issues, individual battery failure within the bank, and electromotive forces or snapbacks that drive peak system currents or temperature events over the current or temperature protection capability of the BMS in any one of the individual batteries in the string. These events are not within the manufacturers control. Good system designers should build in margins of error.

4. How to charge lithium batteries in parallel

Overall battery performance is related to charge/discharge rates; to the temperature during the electro-chemical processes taking place during charge/discharge; to all of the inter-battery connections, and to a batteries age. Each of these are related to, or contribute to resistance.

4.1 Resistance is the enemy

Resistance - and changes in resistance over time - come from the battery's internal component design; from changes in internal resistance during the charge/discharge electro-chemical process; changes in temperature, and from resistance added to the electrical circuit in the form of battery terminals, terminal connectors and more.

NOTICE

To achieve well balanced discharge and charge processes and to maintain a balanced battery bank, it is imperative that we do everything possible to ensure each battery is exposed to the same discharge loads and charging voltage, so we need to make sure that the resistance to either is the same at all points within the battery bank.

NOTE

While it is against our recommendation to do so, in an emergency it is possible to connect different types of batteries in parallel. However, if you do so, you can be sure the bank will fail prematurely because they will have different internal resistance variants to discharge and charge processes which causes constant out of balance, depth of discharge and state of charge conditions.

When training our customer service groups on battery failure diagnostics, failure mode analysis and customer support, some of the questions they are trained to ask are:

1. How is the battery installed? Is it in parallel? Is it in series? Is it in a series and parallel installation?
2. If installed in parallel, which battery in the string has failed?
3. Are all of the batteries in the string of the same type (AGM, GEL, Flooded, Lithium), the same capacity and the same age?
 - a. You would be surprised to learn how many installations we see with mixed battery types!
4. How are the batteries connected? Can you send me a diagram please?
5. When reviewing the wiring diagram, are all of the connector cables the same size and length?
6. Are all of the cable ends properly crimped and free of corrosion?
7. Do any of the battery terminals have more than two cable ends attached?
8. Are there any accessories tapping off of individual batteries in the string or are "all" loads being evenly applied across all batteries?
9. Are there common Positive and Negative BUS bars used in the installation?

Essentially all of these questions are related to identifying potential points of *resistance* within the bank which eventually lead to premature battery failure.

4.2 How to charge lithium batteries in parallel - from bad to best designs

Figure 6 illustrates from BAD to BETTER, different ways to connect and organise loads and charge sources to ensure your parallel bank remains in balance and premature failures are avoided. To be clear it is all about managing resistance so that each battery in the string is sharing the same amount of amperage during charge and discharge with no battery having to work harder than another.

NOTICE

In addition to the need for a consistent number of interconnecting leads for each battery, the length and size (wire gauge) of the connectors should be the same when building battery banks. In order to maintain a balanced resistance across the whole battery bank do everything you can to make sure that the length and wire gauge of each connector (conductor) are the same.

Even though the following BAD, GOOD, BETTER and BEST configuration drawings have the appearance of uneven conductor lengths you must do everything in your power to ensure your installation does not have different wire lengths and sizes and that all cable ends are properly crimped and soldered. **RESISTANCE IS YOUR ENEMY!**

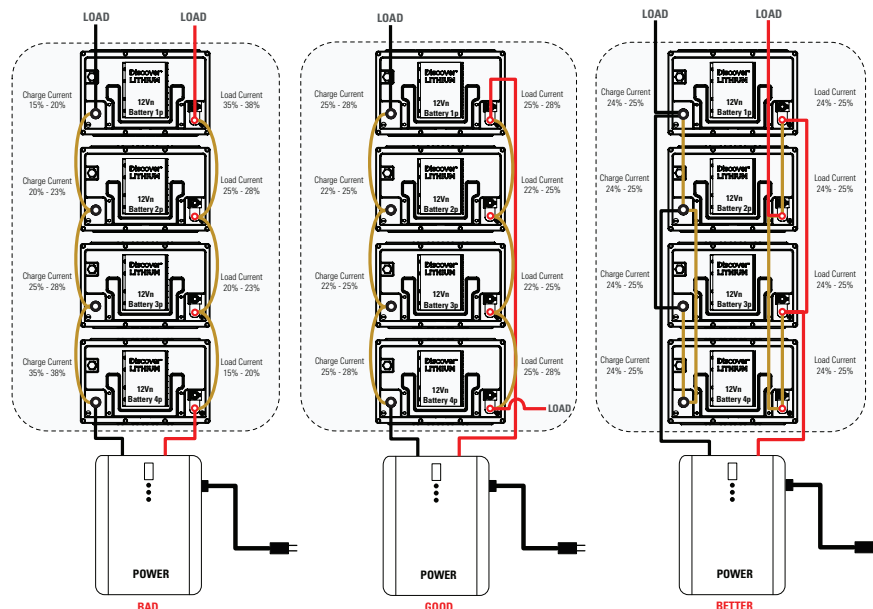

Figure 6: Cabling options for charging batteries in parallel

BAD parallel charging design: Because of uneven resistance levels Battery 4 in the BAD configuration in figure 6, is going charge faster and discharge slower than Battery 3 which in turn will charge faster and discharge slower than Battery 2 which in turn will charge faster and discharge slower than Battery 1. The differences in internal resistance from Battery 4 to Battery 1 can generate a 50% difference in the amount of charge and load currents experienced. This is not how you want to connect your parallel bank if you want to avoid premature performance loss and early battery failure.

GOOD parallel charging design: The GOOD wiring configuration in Figure 6 presents a better way of making connections to loads and chargers and will go a long way towards eliminating problems with unbalanced discharge and charge performance. By improving the distribution of resistance across all of the batteries and connections, each battery is better able to maximise its performance and life. To achieve this improvement, you simply need to make your charge and load connections from either side (opposite ends) of the parallel bank. In this GOOD example current will pass through three interconnecting leads with no more than a 15% difference between Battery 1 and Battery 2 or Battery 4 and Battery 3. This GOOD method of balanced charging can be used on both even and odd numbered battery strings.

BETTER parallel charging design: Other than there being a few terminals with more than two connectors attached, this BETTER method of wiring your parallel battery banks will result in the same amount of current being drawn from each battery during the discharge and charge process. It will maximize the performance and life of all your batteries as they will be charged and discharged evenly. This method of charging can be utilized when there is an even number of batteries (4, 6, 8, etc.)

Finally, as shown in the BEST option, wherever possible use Positive and Negative BUS bars to collect and distribute your load and charge circuits taking care to cross connect loads and charge sources.

BEST parallel charging design: The BEST method of wiring your parallel battery banks is to use **POS. (+)** and **NEG. (-)** BUS Bars as shown in Figure 7. Make sure the cable lengths and sizes between the battery terminals and the BUS bar and the batteries are the same. Do your best to make sure that the **POS. (+)** and **NEG. (-)** charge source cable lengths and sizes are the same and also that the cabling of each of the loads are of the same length and size. This BEST method can be used on both even and odd numbered battery strings.

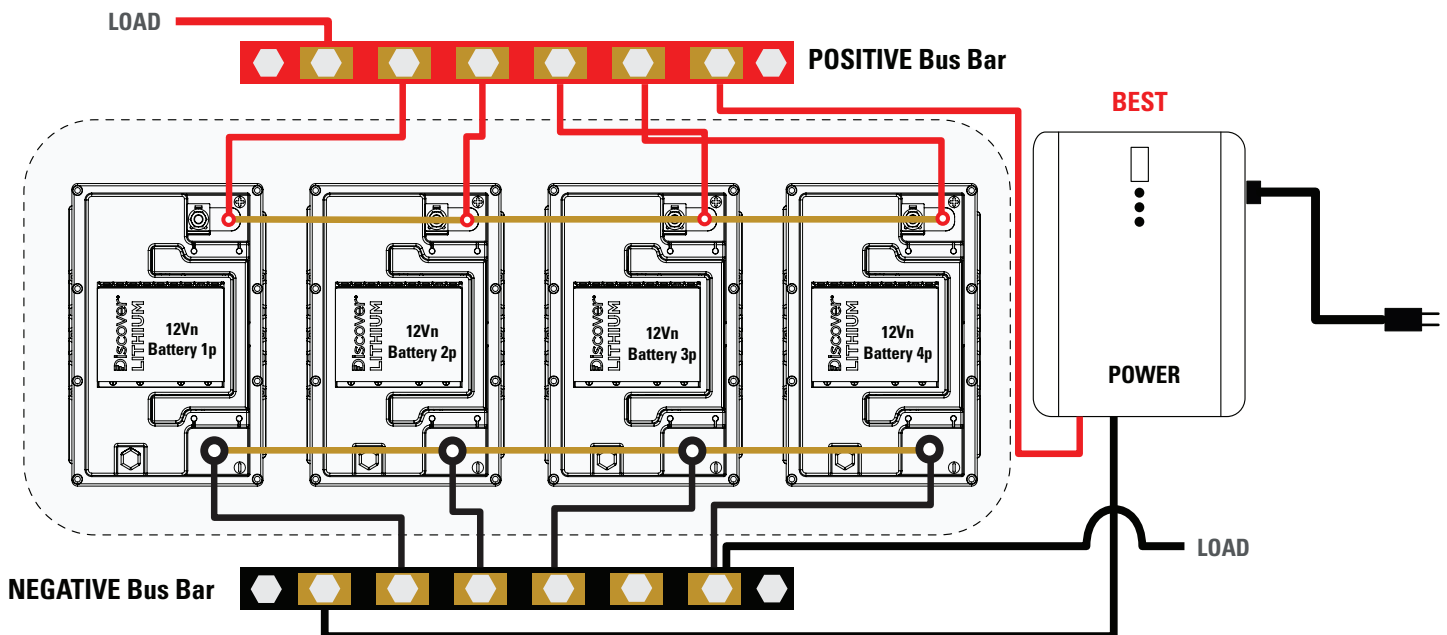

Figure 7: Parallel connection 4P x 12Vn = 12V

NOTE

When charging in parallel always allow Discover designed Lithium batteries to be left charging at their absorption/balancing voltage for extended periods. Doing so Allows the batteries to balance and will help ensure that the total battery bank will remain in balance.

NOTICE

Lithium batteries are easy to charge and discharge. Because their efficiency is near 99% at charge currents below 1C, and they discharge nearly 98% of their capacity at or above 3Vpc (12V for a 12-volt model) they can easily be charged at the lowest of voltage settings. There is "NO REASON" to push the upper voltage limits of the cell technology and if you are going to error when it comes to charging voltage then error on the low side and set you maximum charge voltage settings at or just above the batteries absorption voltage or in the case of LiFePO4 between 13.6 and 14.2 volts for a 12 volt battery.

5. How to connect lithium batteries in series and parallel

Batteries are connected in series to increase the nominal voltage rating – without increasing the capacity - of one individual battery to the operating voltage requirements of the application. Batteries are connected in parallel to increase the amp-hour capacity – without increasing the voltage - of an individual battery to the capacity or run-time needs of the application. Batteries can be combined in both series and parallel to build a battery bank that combines both an increase in voltage and an increase in amp-hour capacity. Series parallel battery bank cabling/connections seem daunting at first but with a little preparation and some practise on paper the process can be simplified and performed by anyone. It is good practise to label the batteries in each string. String one includes batteries 1A and 1B. String two includes batteries 2A and 2B.

⚠ CAUTION

Series and Parallel battery bank cabling/connections seem daunting at first but with a little preparation and some practise on paper the process can be simplified and performed by anyone. It is good practise to label the batteries in each string. In Figure 8 string one includes batteries 1A and 1B and string two includes batteries 2A and 2B. Anytime we consider making multiple connections across multiple batteries we must take safety into consideration and pay close attention to fusing, short-circuit, accidental grounding and reverse-polarity protection as we make the many connections. Extreme caution and attention to detail must be taken to avoid improper cabling and terminal connections and to avoid terminal arching. In addition to the personal risks presented, battery or BMS damage from arch faults or short circuits will void warranty.

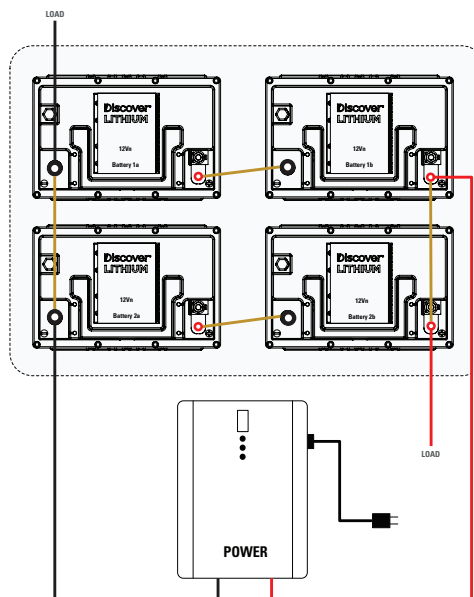

Figure 8: Series and parallel bank using 2 strings of 2 x 12V batteries in series then paralleled

Figure 8 is a diagram of a series connected string of 2 x 12.8V 100AH batteries connected in parallel with another series connected string of 2 x 12.8V 100AH batteries to create a 25.6V 200 AH battery bank with 5120W of stored energy.

NOTE

“Volts x Amps = Watts”: One 12.8V x 100AH = 1280W. Two 12.8V x 100AH batteries connected in series = 25.6V 100AH with 2560W of stored energy. Two series strings paralleled together create a 24V 200AH battery bank with 5120W of stored energy

NOTICE

Instead of designing a series and parallel bank as shown in figure 8, consider using higher voltage Discover lithium battery solutions and paralleling them up to you're your desired capacity and maximum continuous current needs. This can also include paralleling additional strings for system redundancy. See Figure 5.

NOTE

Installers should always avoid connecting loads and charging/power sources to the same battery in a completed bank. Properly ensuring that loads and charging source connections are made to opposing ends of the string will ensure the bank stays in balance and can prevent premature battery failure.