

Discover[®]

ADVANCED ENERGY

Lithium Ion Battery

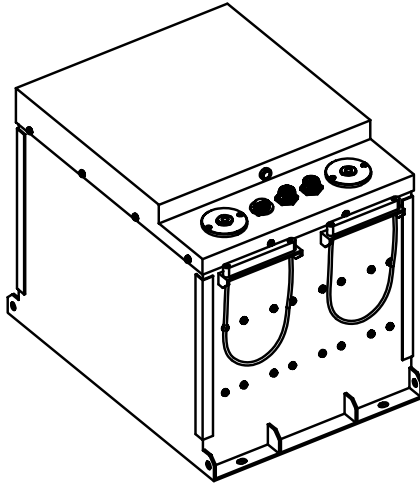

AES LiFePO₄ INSTALLATION AND OPERATION MANUAL - AUSTRALIA

BATTERY MODEL

42-48-6650

- 1. AUDIENCE, SAFETY, MESSAGES, AND WARNINGS 3**
 - 1.1 Audience. 3
 - 1.2 Warning, Caution, Notice, and Note Messages. 3
 - 1.3 General Warnings 4
 - 1.4 Safe Handling Procedures. 5
 - 1.5 Personal Protective Equipment. 5
- 2. ITEMS SHIPPED IN THE BOX. 6**
- 3. SPECIFICATIONS 6**
 - 3.1 Electrical Specifications. 6
 - 3.2 Mechanical Specifications. 7
 - 3.3 Environmental Specifications. 7
 - 3.4 Protection Specifications. 7
 - 3.5 Regulatory 9
- 4. TRANSPORTATION 9**
- 5. HANDLING 9**
- 6. FEATURES 9**
 - 6.1 Internal Battery Fuse 10
 - 6.2 ON/OFF Key 10
 - 6.3 AEBus Port (LYNK Port) 10
 - 6.4 Equipment Ground 11
- 7. THEORY OF OPERATION 11**
 - 7.1 Ingress Protection IP55 11
 - 7.2 Battery Management System 12
 - 7.3 AEBus (LYNK) Network Communication 13
- 8. OPTIONAL ACCESSORIES 13**
- 9. INSTALLATION 14**
 - 9.1 Tools 14
 - 9.2 Location 14
 - 9.3 DC Cables 15
 - 9.4 Protection 15
 - 9.5 Securing the Battery 16
 - 9.6 Installing the Battery 17
 - 9.7 Installing Batteries in Parallel Battery Wiring. 18
 - 9.8 AEBus (LYNK) Network 20
- 10. OPERATION 22**
 - 10.1 Low Voltage Cut-Off. 22
 - 10.2 State of Charge 22
 - 10.3 Charging. 22
 - 10.4 Charging Profile. 23
- 11. ROUTINE INSPECTION 25**
- 12. STORAGE 25**
- 13. BATTERY MODULE FIRMWARE AND DATA LOGS 26**
- 14. TROUBLESHOOTING 26**
- 15. RELATED INFORMATION 26**
- 16. GLOSSARY OF TERMS, ABBREVIATIONS, AND ACRONYMS 26**

Introduction

The AES LiFePO₄ is a battery that can operate on its own or in a battery bank configuration where multiple batteries are connected in parallel.

This Manual covers serial numbers for part number 42-48-6650 greater than DET424820275xxxx.

1. AUDIENCE, SAFETY, MESSAGES, AND WARNINGS

1.1 Audience

Configuration, installation, service, and operating tasks should only be performed by qualified personnel in consultation with local authorities having jurisdiction and authorized dealers. Qualified personnel should have training, knowledge, and experience in:

- Installing electrical equipment
- Applying applicable installation codes
- Analyzing and reducing hazards involved in performing electrical work
- Installing and configuring batteries
- Installing and configuring systems activated by relays

1.2 Warning, Caution, Notice, and Note Messages

Messages in this manual are formatted according to this structure.



Additional information concerning important procedures and features of the product. Read all the instructions before installation, operation, and maintenance.



Important information regarding hazardous conditions.

⚠ WARNING

Important information regarding hazardous conditions that may result in personal injury or death.

⚠ CAUTION

Important information regarding hazardous conditions that may result in personal injury.

NOTICE

Important information regarding conditions that may damage the equipment but not result in personal injury.

NOTE

Ad hoc information concerning important procedures and features unrelated to personal injury or equipment damage.

1.3 General Warnings



Do not crush, disassemble or dispose of the battery module in fire or the garbage.



This product is made of recyclable materials and must be recycled.



⚠ WARNING

ELECTRIC SHOCK AND FIRE HAZARD

- This equipment must only be installed as specified.
- Do not disassemble or modify the battery.
- If there is damage to the battery case, do not touch exposed contents.
- There are no user-serviceable parts inside.

Failure to follow these instructions may result in death or serious injury.

⚠ WARNING

CHEMICAL HAZARD

- Do not touch the exposed contents of a Lithium cell.

Failure to follow these instructions may result in death or serious injury.

⚠ WARNING

ELECTRIC SHOCK AND FIRE HAZARD

- Do not lay tools or other metal parts on top of the battery or across the terminals.

Failure to follow these instructions may result in death or serious injury.

⚠ CAUTION

ELECTRIC SHOCK HAZARD

- Do not touch the energized surfaces of any electrical component in the battery system.
- Before servicing the battery, follow all procedures to fully de-energize the battery system.
- Follow the “Safe Handling Procedures” below when working with the battery.

Failure to follow these instructions may result in injury.

1.4 Safe Handling Procedures

Before using the battery, read all instructions and cautionary markings on the unit and all appropriate sections of this manual.

- Use personal protective equipment when working with batteries.
- Do not dispose of the battery in a fire.
- Promptly dispose of or recycle used batteries following local regulations.
- Do not disassemble, open, crush, bend, deform, puncture or shred.
- Do not modify, re-manufacture, or attempt to insert foreign objects into the battery, immerse or expose the battery to water or other liquids, fire, explosion, or other hazards. If the user suspects damage to the battery module due to water, heat, or other reason, take it to a service center for inspection.
- Only use the battery for the system for which it is specified.
- Do not lift or carry the battery while in operation.
- The battery is heavy. When lifting the battery, follow appropriate standards.
- Only lift, move, or mount following local regulations.
- Take care when handling battery terminals and cabling.
- Only use the battery with a charging system that meets specifications. Using a battery or charger that does not meet specifications may present a risk of fire, explosion, leakage, or other hazards.
- Do not short-circuit a battery or allow metallic conductive objects to contact battery terminals.
- Replace the battery with only another battery that meets the specifications for the system. Using a battery that does not meet specifications may present a risk of fire, explosion, leakage, or other hazards.
- Do not drop the device or battery. If the device or battery is dropped, especially on a hard surface, and the user suspects damage, take it to a service center for inspection.

1.5 Personal Protective Equipment

When handling or working near a battery:

- Use Personal Protective Equipment, including clothing, glasses, insulated gloves, and boots.
- Do not wear rings, watches, bracelets, or necklaces.

2. ITEMS SHIPPED IN THE BOX

Table 2-1, AES LiFePO₄ box contents

Items	Description
1	Battery
1	Terminator
1	Splitter
1	Terminal cover (black)
1	Terminal cover (red)
2	M8 bolt
1 set	Safety warning decals

3. SPECIFICATIONS

All specifications in this document are published @25°C / 77°F.

3.1 Electrical Specifications

Table 3-1, AES LiFePO₄ Electrical Specifications

Electrical Specifications	42-48-6650
Nominal Voltage	51.2 V
Nominal Energy	7.39 kWh
Usable DOD	90%
Rated Wh Capacity (1C)	6.65 kWh
Rated Ah Capacity (1C)	130 Ah
Charge Bulk Voltage - Bulk VDC	54.4 Vdc
Charge Absorption Voltage - U1 MAX	54.4 Vdc
Charge Float Voltage - U2	53.6 Vdc
Charge Termination Current ^(a)	2 A
Low Voltage Disconnect Recommended	48.0 V
Low Voltage Disconnect ^(b)	40.0 V
Max. Continuous Discharge Current	130 Adc
Max. Continuous Charge Current	130 Adc
Peak Discharge Current (3 seconds)	300 Adc
Fuse (Provides backup overcurrent protection)	200 A
Maximum short circuit fault current	6.0 kA / 5.5 ms
Arc Flash Incident Energy IEm	0.1 cal/cm ²
Arc Flash Incident Energy AFB	9.4 cm
^(a) Charge termination current is permitted to be less than specified. ^(b) Under load, low Voltage Disconnect is based on 2.5VPC. In no load conditions, do not allow the battery to self-discharge below 3.0 VPC.	

3.2 Mechanical Specifications

Table 3-2, AES LiFePO₄ Electrical Specifications

Mechanical Specifications	42-48-6650
Chemistry	LiFePO ₄
Length	471.5 mm (18.56 in)
Width	347.5 mm (13.68 in)
Height	375 mm (14.76 in)
Terminal (1)	M8
Weight	870 kg (191.8 lb)
IP Rating	IP55
Case Material	Powder Coated Cold Rolled Steel
<small>(1) TERMINAL TORQUE: 9 Nm +/- 3 (6.64 ft-lb) to a maximum depth of 14 mm.</small>	

3.3 Environmental Specifications

Table 3-3, AES LiFePO₄ Environmental Specifications

Environmental Specifications	42-48-6650
Charge Operating Temperature Range ^{(a)(b)}	0°C to 45°C (32°F to 113°F)
Discharge Operating Temperature Range ^(a)	-20°C to 50°C (-4°F to 122°F)
Storage Temperature ^(c)	-20°C to 45°C (-4°F to 113°F)
<small>(a) Specifies the temperature of the cells and not the ambient temperature. Ambient temperature and cell temperature may not be the same.</small>	
<small>(b) The Battery Management System (BMS) does not allow charging of cells when it is below 0°C (32°F).</small>	
<small>(c) Storage outside of specified temperatures will result in permanent capacity loss and void the warranty.</small>	

3.4 Protection Specifications

Table 3-4, AES LiFePO₄ Protection Specifications

Protection Specification	42-48-6650
Overvoltage	
Protection ^(a)	Greater than 58.4 V for 3 seconds
Recovery ^(a)	Recovery after 120 seconds. Charge is permitted at 53.6 V or less
Undervoltage	
Protection ^(b)	Less than 40 V for 5 seconds
Recovery ^(b)	No automatic recovery. The battery shuts down after 120 seconds.
Over-Charge Current	
Protection	Greater than 143 A for 10 seconds
Recovery	Recovery after 120 seconds

Over-Discharge Current	
Protection (c)	3-second rating 300 A
Recovery (c)	Recovery after 120 seconds
Over-temperature in Discharge	
Protection (d)	Cell temperature above 60°C (140°F) for 5 seconds
Recovery (d)	Cell temperature below 50°C (122°F)
Under-temperature in Discharge	
Protection (d)	Cell temperature below -20°C (-4°F) for 5 seconds.
Recovery (d)	Cell temperature above -18°C (0°F)
Over-temperature in Charge	
Protection (d)	Cell temperature above 60°C (140°F) for 5 seconds
Recovery (d)	Cell temperature below 50°C (122°F)
Under-temperature in Charge	
Protection (d)	Cell temperature below 0°C (32°F) for 5 seconds and charge current detected.
Recovery (d)	Charge recovery temperature above 2°C (36°F) Note: Discharge is available to -20°C (-4°F)
<p>(a) Overvoltage protection monitors individual cell voltages. Protection is triggered when any cell is over 3.65 VPC and recovers after 120 seconds. Charge is permitted when VPC is 3.35 or less. Voltages are provided for guidance only.</p> <p>(b) Undervoltage protection monitors the voltage of individual cells. Protection is triggered for any cell below 2.5 VPC for 5 seconds, and then the battery is automatically set OFF after 120 seconds. Manually set the battery ON to recover. Voltages are provided for guidance only.</p> <p>(c) For time versus current interrupt details, see Figure 2, Over-Discharge Protection Time Current Curve.</p> <p>(d) Specifies the temperature of the cells and not the ambient temperature. Ambient temperature and cell temperature may not be the same.</p>	

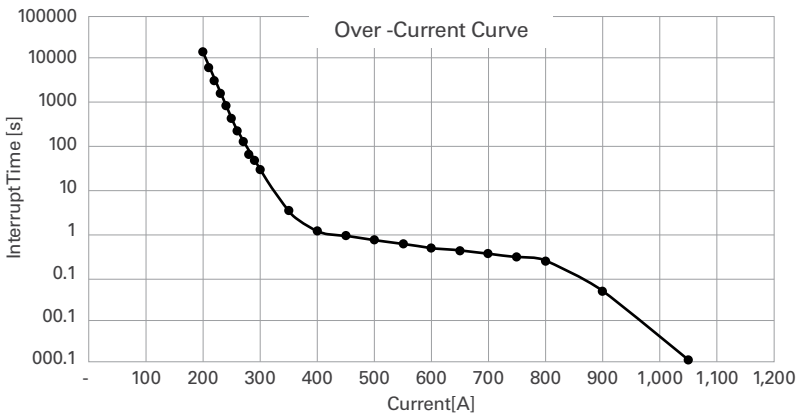

Figure 1. Over-Discharge Protection Time Current Curve

3.5 Regulatory

Table 3-5, 42-48-6650 Regulatory

Regulatory
UN 38.3 Transportation
IEC 62133
UL 1973
UL 2271
UL 9540 (1)
CE
(1) Applies when the battery is used with Schneider Electric inverter-chargers.

4. TRANSPORTATION

If the battery is not installed in the equipment, transport it in the original package or equivalent. Per the UN Handbook of Tests and Criteria, batteries are tested to part III, subsection 38.3 (ST/SG/AC.10/11/ Rev. 5). For transportation, the battery belongs to category UN3480, Class 9.

5. HANDLING

Before handling:

- Keep the battery away from sparks and flames
- Disconnect the cables from the battery
- Protect battery terminals from short-circuiting and touch
- Do not lift or carry the battery while it is in use or in operation
- Do not lift the battery by attached battery cables

6. FEATURES

Item	Description
1	Battery negative (-) black, M8 female
2	ON/OFF key
3	Battery positive (+) red, M8 female
4	Xanbus Port
5	AEBus Port (LYNK Port)
6	USB Port (Type B)
7	Mounting Points
8	Handles

Figure 2. AES Battery

6.1 Internal Battery Fuse

The internal battery fuse provides backup overcurrent protection.

NOTE

Additional external DC fusing is required to protect the battery cables from DC overcurrent and to meet installation codes.

6.2 ON/OFF Key

Press the battery's ON/OFF key for 2 to 3 seconds to switch the battery either ON or OFF. The LED illuminates when the battery is ON and darkens when the battery is OFF.



⚠ WARNING

ELECTRIC SHOCK HAZARD

- Always assume the battery's main relay is ON (Closed), even if the LED for the ON/OFF key is not illuminated.
- Verify the terminal voltage with a voltmeter before handling and installing the battery.

Failure to follow these instructions may result in death or serious injury.

ON/OFF LED	Description
Dark	The battery's main relay is OFF (Open).
Illuminated	The main relay is ON (Closed), and the battery is ready for operation.
Flashing at 1 Hz interval	The main relay is OFF (Open). The flashing indicates protection has been triggered as one or more operating parameters (voltage, current, temperature) have exceeded their fault threshold. Refer to Table 3-4, Protection Specifications , for information on faults that trigger protection.

6.3 AEBus Port (LYNK Port)

The AEBus Port (LYNK port) enables multiple Discover batteries to communicate and interact in a closed-loop network. The AEBus Port also enables AES LiFePO₄ batteries to be networked in a closed-loop system with other networked devices such as external power conversion and motor control devices. A closed-loop system enhances safety and optimizes system performance.

6.3.1 AEBus Port (LYNK Port) Communication RJ45 Pin Assignment

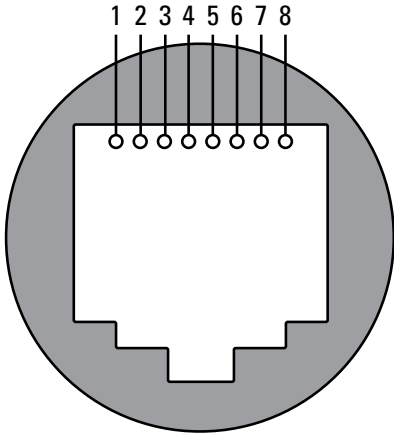
 <p>Figure 3. AEBus Port (LYNK Port) Communication RJ45 pin assignment</p>	Pin Number	Function
	1 (1)	Reserved. Do not use.
	2 (1)	Reserved. Do not use.
	3 (1)	Reserved. Do not use.
	4	CAN Low
	5	CAN High
	6 (1)	Reserved. Do not use.
	7	CAN Ground
8	CAN Ground	
<p>(1) Do not populate. Do not terminate to power. Do not terminate to ground. Do not terminate to CAN_L or CAN_H.</p>		

NOTICE

- Isolate unused pins. Crossing PIN functions may cause system damage.
- Do not terminate unused wires to ground, power, or other functions.
- Mixing the AEBus Network with other networks may result in equipment malfunction and damage.

6.4 Equipment Ground

Grounding the battery is not required.

7. THEORY OF OPERATION

7.1 Ingress Protection IP55

Ingress protection rates the degree of protection provided by mechanical casings and electrical enclosures against intrusion, dust, accidental contact, and water under specified conditions. The IP55 rating indicates that the product is touch-proof and protected from limited dust ingress. And protect from low-pressure water jets from any direction.

IP codes guide suitability for use under different environmental conditions. IP ratings do not indicate fitness for purpose or confer a performance guarantee.

7.2 Battery Management System

7.2.1 Battery Management System Protections

The Battery Management System's (BMS) primary function is to monitor cell module voltage, temperature, and battery current. The BMS uses this information to maintain cell operation within operating specifications. If a parameter falls outside of operating specifications, the BMS will disconnect and protect the battery from:

1. **Overvoltage:** Charge voltages that are too high.
2. **Undervoltage:** Discharged voltage that is too low.
3. **Overcurrent:** Current is too high when powering up a load (high inrush current) or from a sustained charging or discharging current above the specified limit.
4. **Over-temperature:** Cell temperature that is too high during charge and discharge.
5. **Under-temperature:** Cell temperature that is too low during charge and discharge.

For trigger and recovery values, refer to **Table 3-4, AES LiFePO₄ Protection Specifications**.

The BMS reconnects when it hits recovery thresholds. Manually switch the battery ON if the BMS disconnects due to low voltage protection. A physical disconnect switch is recommended to reconnect the battery if the system has a constant parasitic draw.

NOTE

- Charge and discharge have different operating temperature limits.
- If the BMS disconnects in response to temperature or current limits, wait for the temperature or current to reach normal operating limits before switching the battery ON.

7.2.2 Battery Management System Pre-Charge System

The battery has a Pre-Charge System to energize external capacitive loads before switching the main relay ON. The maximum input capacitance for a single battery should not exceed the values in Table 3-1, AES LiFePO₄ Electrical Specifications.

NOTICE

- When switching ON batteries, the inrush current may cause the batteries to fault as they energize external capacitive loads. To resolve this, switch the batteries ON again.

7.2.3 Battery Charge and Discharge Settings

In an open-loop configuration, use the specifications provided in this manual to set up the charge and discharge settings manually at the time of installation through the controller of the Power Conversion device. This system contrasts with a closed-loop configuration where the BMS specifies charging and safety settings through a connection with the Power Conversion device.

Closed-loop communication with a Power Conversion device requires using the LYNK II Communication Gateway device from Discover Battery. Refer to the relevant LYNK II Installation and Operation Manual available from the www.discoverbattery.com website, or contact your Discover Battery provider for assistance.

Refer to the appropriate Application Note available from www.discoverbattery.com for the set up of closed-loop parameters and integration with specific brands of solar inverter-chargers, solar charger controllers, mobile inverter-chargers, and industrial chargers.

7.3 AEBus (LYNK) Network Communication

Discover batteries use CAN communication over the AEBus (LYNK) Network to coordinate performance with other batteries and communicate with accessories such as the LYNK Communication Gateway.

NOTICE

- Terminating resistors are required when deploying the battery in an AEBus (LYNK) Network.

7.3.1 AEBus (LYNK) Network Power

The Discover battery provides the AEBus (LYNK) Network power through the AEBus (LYNK) Port.

NOTICE

- Do not use an external power source to power devices over the AEBus (LYNK) Network.

7.3.2 7.3.2 AEBus (LYNK) Network Size

One AEBus (LYNK) Network can support up to 13 AES LiFePO₄ batteries.

7.3.3 AEBus (LYNK) Network Cable

Use CAT5 cables for batteries on the AEBus (LYNK) Network.

8. OPTIONAL ACCESSORIES

The following optional accessories are available for the AES LiFePO₄ battery.

Accessory	Part Number
LYNK II Communication Gateway	950-0025
AES LiFePO ₄ Wall-Mount Bracket	950-0018

9. INSTALLATION

WARNING

ELECTRIC SHOCK HAZARD

- This equipment must only be installed as specified.
- Do not disassemble or modify the battery.
- If the battery case has been damaged, do not touch exposed contents.
- There are no user-serviceable parts inside.

Failure to follow these instructions may result in injury.

NOTICE

- Some chargers and inverters support temperature-compensated charging. Disable temperature-compensated charging on the charger or inverter.
- Do not use or install a battery temperature sensor.

NOTE

- It is the responsibility of the installer to ensure that all applicable installation requirements and standards are met.

9.1 Tools

- Insulated tools sized to match nuts, bolts, and cables
- RMS type Voltmeter
- Post cleaner and wire brush
- Personal protective equipment

9.2 Location

Install the battery in locations that meet the following requirements:

1. **Do not install in direct sunlight.** Avoid installing the battery in an area with high ambient temperature or an area exposed to UV rays.
2. **Moderate temperature.** The ambient temperature should be between 0°C and 40°C (32°F and 104°F). Ambient temperatures of 15°C to 25°C (59°F to 77°F) are ideal for extending LiFePO₄ battery life. Do not install in close proximity to a generator or other component that produces significant heat, as this could expose the battery to temperatures greater than 40°C (104°F).
3. **Ventilation.** Do not install in zero-clearance compartments.
When installing a single battery, allow spacing of at least 25 mm (1 in) around the perimeter of the battery.
When installing multiple batteries, allow spacing of at least 10 mm (0.4 in) between batteries.
When installing multiple batteries vertically in tiers, allow at least 25 mm (1 in) between a battery and the rack above it, except for the top tier of batteries. Allow a clearance of at least 150 mm (5.9 in) between the top battery and the roof of the enclosure.

4. **Away from water.** Protect from exposure to water, including water sprayed from nozzles. In a wall-mounted configuration, mount the batteries at least 50 mm (2 in) off the ground.
5. **Orientation.** Install the battery in any direction other than face down. Do not install face-down.
6. **Indoor or outdoor.** Suitable for use indoors. Refer to **Section 3.3, Environmental Specifications** for temperature ranges in which the battery can operate.

NOTE

- Using this product in a location that does not meet requirements will void the warranty.

9.3 DC Cables

⚠ CAUTION

FIRE HAZARD

- Undersized cables can become hot and may potentially catch fire.

Failure to follow these instructions can result in minor to moderate injury.

The DC battery cables should meet the following requirements:

1. **Copper-stranded cable.** DC cables must be stranded, copper, and rated 90 °C minimum. Terminate the cables with lugs that fit the DC terminals.
2. **Minimum cable lengths.** Select a location that minimizes the length of battery cables to reduce voltage drop from the impedance leading to reduced performance.
3. **Appropriate cable gauge.** The cables should be capable of carrying the normally expected current, plus a margin of safety.
4. **Proper polarity.** Positive (+) is connected to positive (+), and negative (-) is connected to negative (-).
5. **Minimum cable lengths.** Select a location that minimizes the length of battery cables to reduce voltage drop from the impedance leading to reduced performance.

9.4 Protection

⚠ CAUTION

FIRE HAZARD

- Undersized fuses and disconnects may become overloaded and potentially cause a fire.
- Fuses and disconnects are required to open before the cable reaches its maximum current carrying capability.

Failure to follow these instructions can result in minor to moderate injury.

Additional DC overcurrent protection and a DC disconnect switch are required to protect the system and DC battery cables.

1. **Appropriate size.** Size the fuses and disconnects following local codes to protect the wiring in the system and are required to open before the cable reaches its maximum current carrying capability.
2. **Install disconnects in both the positive and negative cables.** The disconnect should be located close to the battery and installed in both the positive and negative cables. Local codes may limit how far the protection can be from the battery.

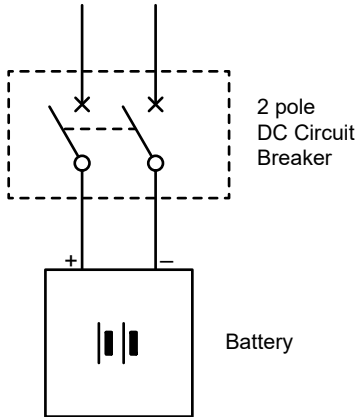

Figure 4. Example disconnect

3. **Install fuse protection in the positive cable.** The fuse should be located close to the battery and installed in the positive cable. Local codes may limit how far the protection can be from the battery.

NOTE

- AC circuit breakers and DC circuit breakers are not interchangeable. Check the label on the circuit breaker to ensure it is the correct type and rating. Use only DC circuit breakers.

9.5 Securing the Battery

Use one of the methods below to secure the battery:

- Strap the battery in place with non-conductive nylon straps.
- Use screws in the hold-down brackets at the base of the 42-48-6650 model (see figure below).
- Secure with a Discover AES Wall-Mount Bracket (p/n 950-0018), available for use with the 42-48-6650 model.

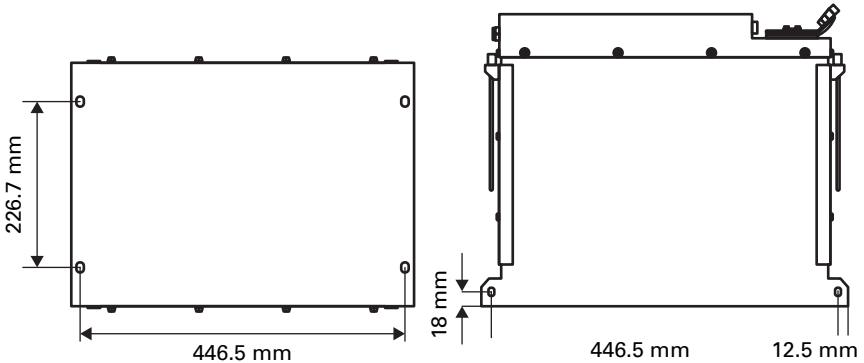

Figure 5. 42-48-6650 screw holes

9.6 Installing the Battery

Battery cables must be sized to the specifications required by the inverter-charger and installed in accordance with the standards set by the authority having local jurisdiction. Do not use or install a battery temperature sensor.

Battery terminals are button-type, M8 female. The recommended torque is 9.0 Nm (6.64 ft-lb) to a maximum depth of 14 mm. For information on connecting battery cables, see Figure 6, Battery Cable Terminal Connection.

1. Switch the battery OFF.
2. If the battery circuit has a disconnect, open the disconnect to isolate the battery.
3. Ensure the cable connections are clean and in good working order.
4. Install and secure the new battery.
 - Take precautions to avoid bridging the terminals.
 - Do not contact the terminals with metal mountings, fixtures, or body parts.
5. Connect battery cables.
 - Connect the negative cable last to avoid sparking.
 - Short circuits may damage the battery and void the warranty.
6. If using the LYNK II Communication Gateway, attach a CAT5 cable to the AEBus (LYNK) Port on the battery and attach the other end of the cable to the LYNK II.
 - Refer to **Section 9.8.2, Network Installation**, for instructions.
7. If the battery circuit has a disconnect, close the disconnect to reconnect the battery.
8. Switch the battery ON.

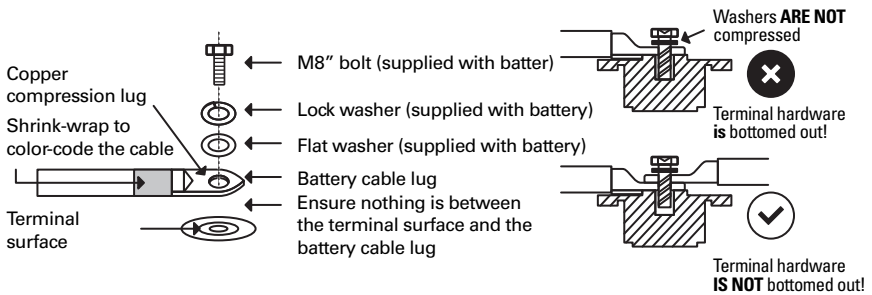

Figure 6. Battery Cable Terminal Connection

NOTE

- All cable ends must be connected to battery terminals without any washers between terminal bushings and cable ends.

Terminal burnout is caused by:

- Discharge currents exceeding allowable limits
- Improper cable installation
- Improper cable sizing
- Improper terminal torque

NOTE

- Without exception, a product experiencing terminal burnout will void the warranty.

9.7 Installing Batteries in Parallel Battery Wiring

For proper balancing and load sharing between parallel batteries, refer to **Figure 7, Batteries in Parallel Installation**. Lithium batteries are very sensitive to voltage, and undersized battery cables impede battery and system performance. The thickness (cross-section) of cables should exceed the recommended minimum for the inverter-charger installation.

When installing four or more batteries in parallel, use a busbar configuration. In a busbar configuration, use the same length cable for all battery cable sets, regardless of the battery's proximity to the busbar (or combiner box). Actual wiring requirements may vary. Consult with the authority having local jurisdiction.

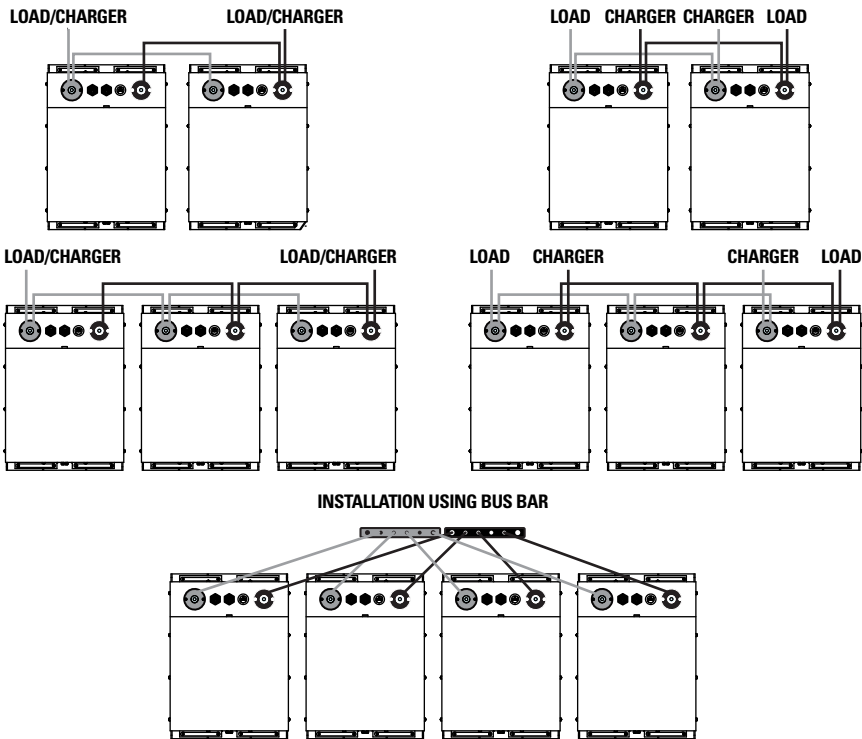

All parallel cables should be the same length

Figure 7. Batteries in Parallel Installation

NOTICE

- An overcurrent protection and disconnection device is required between each parallel battery.

NOTE

- Whenever replacing a battery in a parallel installation, use a battery of the same age, model, capacity, and voltage.
- Before installing the battery in parallel, ensure that each battery is charged to 100% SOC.

9.7.1 Commissioning a Parallel Battery System

In a parallel battery system, charge all batteries to 100% State of Charge (SOC) before switching the batteries ON. Before energizing power electronics, switch all batteries ON.

NOTICE

- Failure to ensure all batteries are at equal SOC when commissioning a paralleling system may result in blown battery fuses.

9.8 AEBus (LYNK) Network

9.8.1 Network Layout

AES batteries use the AEBus (LYNK) Network to coordinate voltage, temperature, and current data. Network terminators are required for the AEBus (LYNK) Network to function properly.

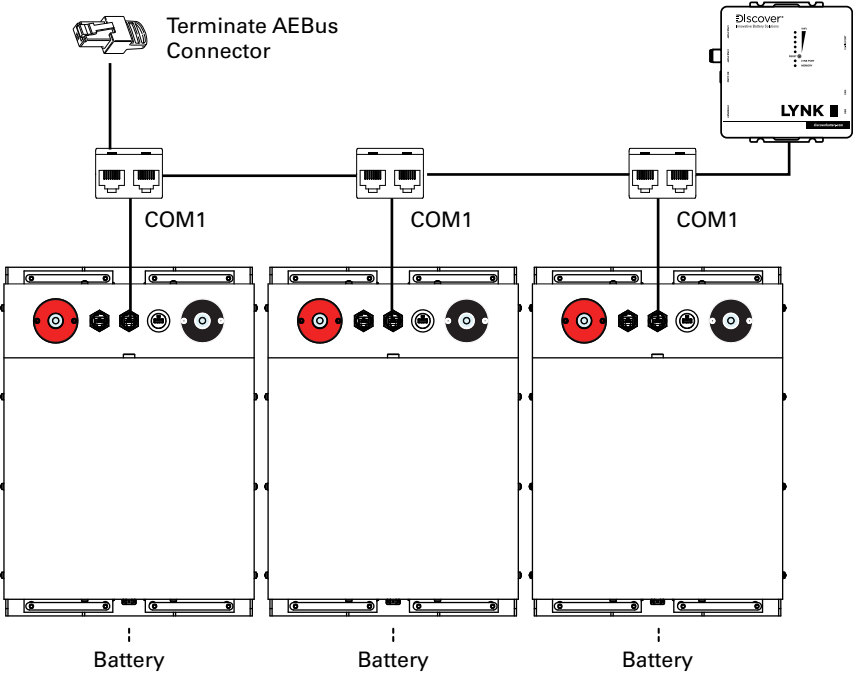

Figure 8. Batteries connected to AEBus (LYNK) Network

9.8.2 Configuration with Power Conversion and Monitoring Devices

Set up AES batteries to work with Power Conversion and Monitoring devices in either an Open-Loop or Closed-Loop configuration. Set up the charge and discharge settings in an Open-Loop configuration through the Power Conversion device's controller at the time of installation. In a Closed-Loop configuration, the BMS of the AES Battery dynamically controls charge and discharge settings over a connection with the Power Conversion device. Closed-Loop communication on a Power Conversion device network requires using the LYNK II Communication Gateway (p/n 950-0025) available from Discover Battery.

For information on Closed-Loop and Open-Loop configuration with a Power Conversion device, refer to the appropriate Application Note for your Power Conversion device, available from the website www.discoverbattery.com, or contact your Discover Battery provider for assistance.

NOTE

- Schneider Electric Conext branded devices communicate over Xanbus, forming a Closed-Loop configuration using the Xanbus Port on the AES battery, and do not require the LYNK II Communication Gateway (p/n 950-0025). For instructions on using Xanbus, refer to **Application Note 885-0013 Closed-Loop Integration with Xanbus Enabled Schneider Electric Conext Products**.

9.8.3 Network Installation

Networking Guidelines:

- **Separate data and power cables.** Allow for separation between data and power cables. Avoid data interference caused by running network cables bundled with power cables.
- **Allow for AEBus (LYNK) Network cable slack.** Ensure that AEBus (LYNK) Network cables are slack and not in tension.
- **Isolate the AEBus (LYNK) Network.** Do not mix other networks with the AEBus (LYNK) Network.

NOTICE

- Mixing the AEBus (LYNK) Network with other networks may result in equipment malfunction and damage.

9.8.4 Installation Procedure

1. Before beginning a network installation, mount the devices according to their instructions.
2. Attach a CAT5 cable to the AEBus (LYNK) Port on a battery.
3. Connect the other end of the CAT5 cable to the AEBus (LYNK) Port of the following battery.
4. Repeat until all batteries are connected.
5. Add a terminator to the last battery in the AEBus (LYNK) Network.
6. Network with other devices and accessories as needed.

9.8.5 Testing and Verification of the AEBus Network

Perform network verification with the **950-0025 LYNK II Communication Gateway**.

- If the LYNK II Network Bus indication LED is illuminated, power and communication for the AEBus (LYNK) Network are active.
- Use LYNK ACCESS software through a computer to confirm the number of batteries in the AEBus (LYNK) Network.

10. OPERATION

The BMS prevents battery operation outside of specified operating conditions. Understand each of these protections and set up the system accordingly.

Refer to **Table 3-4, AES LiFePO₄ Protection Specifications**.

NOTICE

- Intentionally bypassing the BMS to operate the battery outside maximum and minimum limits voids the warranty.

10.1 Low Voltage Cut-Off

Program the low voltage cut-off at or above the Low Voltage Disconnect as shown in **Table 3-1, AES LiFePO₄ Electrical Specifications**. This action disconnects the load before the BMS enters low voltage protection.

NOTICE

- Storing or leaving the battery at 0% SOC will lead to irreversible damage and void the warranty.

10.2 State of Charge

A voltage-based battery meter designed for lead-acid batteries will not provide an accurate state-of-charge (SOC) for lithium batteries. The following device, available from Discover Battery, can be used to communicate an accurate state of charge to other devices.

- LYNK II Communication Gateway

10.3 Charging

Each electrical system will have different characteristics and balance-of-system components. Charger settings may require modifications to optimize system performance.

NOTICE

- Always confirm that the charging device is incapable of producing transient spikes that exceed the published terminal voltage limits for the battery.
- Always confirm the charging curve meets the battery's charging requirement.

NOTICE

- Never charge a visibly damaged or frozen battery.

10.3.1 Closed-Loop Charging

Closed-loop charging is a charging method whereby the battery communicates with a charger and controls the charge voltage and current. Closed-loop charging is available with compatible chargers directly connected to the AEBus (LYNK) Port or through the LYNK II Communication Gateway. Closed-loop charging reduces charge time and increases balancing efficiency when compared to open-loop charging.

Refer to the appropriate Application Note available from www.discoverbattery.com for the set up of closed-loop parameters and integration with specific brands of solar inverter-chargers, solar charger controllers, mobile inverter-chargers, and industrial chargers.

10.3.2 Open-Loop Charging

Open-loop charging is a method of charging where the battery and charger do not communicate. The charger must be configured manually with appropriate settings for open-loop charging.

For charging parameters, refer to **Table 3-1, AES LiFePO₄ Electrical Specifications**.

10.3.3 When to Charge the Battery

- **Opportunity charging is OK:** Charging the battery after every use will not reduce its cycle life.
- **Partial State-of-Charge is OK:** If the battery SOC is greater than 10% at the end of discharge, it does not require an immediate charge.
- **Charge if below 10% SOC:** If the battery is discharged below 10% SOC, it must be charged within 24 hours to avoid permanent damage to the battery. Otherwise, irreversible damage to the battery cells will occur in a very short period of time.
- **Low charge current extends life.** Charging at 50% of nominal current or lower helps extend the battery cycle life.

Charge within the proper temperature range. Ensure that charging is within the charge temperatures specified in **Table 3-3, AES LiFePO₄ Environmental Specifications**.

NOTICE

- The battery must be charged within 24 hours if it has been discharged below 10% SOC. Otherwise, irreversible damage to the battery cells will occur in a very short period of time and void the warranty.

10.4 Charging Profile

Charge with a Lithium charge profile matching the specifications for the AES LiFePO₄ battery.

Standard open-loop charging for the battery should include both Bulk and Absorption phases.

Refer to **Table 3-1, AES LiFePO₄ Electrical Specifications** for open-loop charging parameters.

Refer to the appropriate Application Note available from www.discoverbattery.com for the set up of closed-loop parameters and integration with specific brands of inverter-chargers and battery chargers.

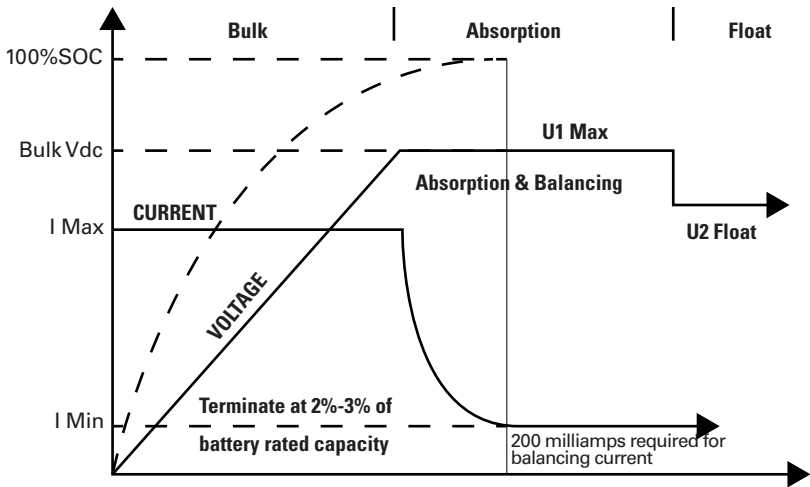

Figure 9. Charge Graph.

NOTICE

- Charge with a Lithium charge profile matching the specifications for the AES LiFePO₄ battery.
- Do not charge using a lead-acid charging profile. Charging using a lead-acid profile will void the warranty.

NOTE

- Charging at 50% of nominal current or lower will extend the battery cycle life.

10.4.1 Bulk Charge

Bulk phase. The Bulk Charge is the first phase of the charging process, also called the constant current phase. This phase is when the charger's maximum current is directed to the battery until reaching the desired voltage. The Bulk phase will recharge the battery to approximately 90-95% SOC.

If the charging source is a generator or other charge source that is not efficient at low output current, a single-stage charge may be appropriate. A single-stage charge will only complete the Bulk phase portion of the charge curve. This method should return the battery to 90-95% SOC.

Refer to **Table 3-1, AES LiFePO₄ Electrical Specifications** for charging parameters.

10.4.2 Absorption Charge

Absorption phase. The second phase of the charging process is Absorption Charge, also called the constant voltage phase. In this phase, the charger reduces current accordingly to maintain the desired voltage.

Refer to **Table 3-1, AES LiFePO₄ Electrical Specifications** for charging parameters.

10.4.3 Equalization Charge

CAUTION

FIRE AND BURN HAZARD

- Do not perform an equalization charge on the AES LiFePO₄ battery.

Failure to follow these instructions may result in minor to moderate injury.

Do not equalize charge the AES LiFePO₄ battery. Equalization charging is intended only for lead-acid batteries. An equalization charge is a purposeful overcharge that targets a voltage above the standard charge voltage to remove sulphate crystals that form on lead-acid plates over time.

10.4.4 Float Charge

Float phase. Float charge, the third phase of charging, is optional. During this stage, the battery is maintained at 100% SOC for extended periods, counteracting any self-discharge or parasitic loads.

- **Not necessary.** Float charging is not required.

Refer to **Table 3-1, AES LiFePO₄ Electrical Specifications** for float parameters if needed.

11. ROUTINE INSPECTION

Periodically inspect the battery.

1. Ensure that all DC cables are secure and fasteners are tight.
2. Ensure all Networking cables and connectors are secure and tight.
3. Ensure that the installation location is clean and free from debris.
4. Inspect for cracks in the battery case.
5. Replace any damaged batteries.
6. Replace any damaged cables.

The battery is ready for use after the inspection is complete.

12. STORAGE

Leaving the battery connected to a trickle load or power electronics will cause the battery to discharge during storage. Without any load, the battery will self-discharge by approximately 3% per month while in storage. After storage, charge the battery to 100% SOC and perform at least one full discharge and charge cycle before returning the battery to service.

1. **Store at 95% SOC or more.** To store the battery for up to 6 months, store the battery at 95% SOC or more. It must remain disconnected from all loads and power electronics during storage.
2. **Switch OFF the battery.** Set the battery to OFF.
3. **Check SOC every 6 months.** Recharge the battery to above 95% SOC at least every 6 months.

4. **Proper storage temperature.** Ensure storage is within the temperatures specified below.
- -20°C to 45°C (-4°F to 113°F)

NOTICE
<ul style="list-style-type: none"> • Leaving the battery connected to a load or power electronics during storage may subject the battery to discharge, resulting in irreversible damage and voiding the warranty.

NOTICE
<ul style="list-style-type: none"> • Storing the battery outside specified temperatures will result in irreversible damage and void the warranty. • Storing or leaving the battery at 0% SOC will result in irreversible damage and void the warranty. • Allowing the battery to self-discharge below an open-circuit voltage of 3.0 VPC will cause irreversible damage and void the warranty.

13. BATTERY MODULE FIRMWARE AND DATA LOGS

Always ensure the battery is using the latest firmware. AES Dashboard PC software is required to update the battery firmware and to download data logs from the battery. Get the latest software and battery operating firmware from the Discover Battery website at www.discoverbattery.com.

14. TROUBLESHOOTING

Accurate troubleshooting and warranty claims require data logs from each battery. Use AES Dashboard diagnostic software to download data logs one battery at a time.

Confirm you have the latest version of Dashboard, which was AES Dashboard 7.0.6_win64 at the time of publishing. System owners are encouraged to install the AES Dashboard software on a laptop to troubleshoot their system.

15. RELATED INFORMATION

For warranty information, refer to 885-0046 Discover AES LiFePO₄ Battery Warranty Policy, available from the Discover Battery website at www.discoverbattery.com.

16. GLOSSARY OF TERMS, ABBREVIATIONS, AND ACRONYMS

VPC Volts Per Cell	LFP LiFePO ₄ Lithium Iron Phosphate
BMS Battery Management System	SOC State of Charge
DOD Depth of Discharge	

